

v. 20230713

BFFT10R

OWNER'S MANUAL

WARNING LABELS

THERE IS A RISK ASSUMED BY INDIVIDUALS WHO USE THIS TYPE OF EQUIPMENT. TO MINIMIZE RISK, YOU MUST FOLLOW THESE RULES:

Inspect equipment before each workout. Check that all nuts, bolts, screws and pop pins are in place and fully tightened. Also, before use, check cables for sign of wear. Replace all worn parts immediately. Never use machine if any parts are damaged or missing.

FAILURE TO FOLLOW THESE RULES MAY RESULT IN SERIOUS INJURY.

Keep clear of the cables and all moving parts when machine is in use.

Always make sure all Snap Links are closed when doing cable/pulley/strap exercises.

Exercise with care. Perform your exercises at a smooth moderate pace; never perform jerky or uncoordinated movements that may cause injury.

It is recommended that you workout with a training partner.

Do not allow children or minors to play on or around this equipment.

If unsure of proper use of equipment, call your local Best Fitness distributor or the Best Fitness customer service center at 1-800-556-3113.

WARNING: Consult your physician before starting your exercise program. For your own safety, do not begin any exercise program without proper instruction.

WARNING!

Safety and Maintenance of Cables

IMPORTANT: Cables are wear items. It is your responsibility to prevent unexpected breakage. **Cable inspection should be performed daily.**

Inspect all cables, the nylon coating on all cables, and the area near fitting at each end of each cable.

Replace and damaged or worn cable immediately.

Do not allow the machine to be used until damaged or worn cables are replaced. Using or allowing a machine to be used with a suspect cable can result in serious injury. See Owner's Manual for more information.

For Best Fitness Customer Service
Call 1-800-556-3113

MAINTENANCE SCHEDULE

Check the function and integrity of the following components. As noted, inspect equipment before each workout. Replace all damaged, broken or worn components immediately.

Cables:	Check tension, end fittings, and coating	✓	
	Check that locking nut at weight stack is tight		✓
Upholstery:	Wipe down and dry	✓	
	Clean and condition		✓
Frame:	Wipe down and dry	✓	
	Polish / Wax		✓
Chrome:	Wipe down and dry	✓	
	Polish / Lubricate		✓
Nut / Bolts / Fasteners:	Tighten and / or adjust as needed		✓
Guide Rods:	Lubricate and clean		✓
Linear Rods:	Lubricate and clean		✓
Seat Sleeves:	Lubricate and clean		✓
Adjustments / Locking Pins / Tightening Knobs			✓
Weight Stack Pins			✓
Warning Instruction Labels			✓
Springs / Pop Pins		✓	
Anti Skid Surfaces			✓
Hand Grips / Rollers			✓

For Body-Solid Customer Service
Call 1-800-556-3113
#MSSTKR0808

TABLE OF CONTENTS

SAFETY INSTRUCTIONS.....	PAGE 4
PREPARATION.....	PAGE 5
HARDWARE LIST.....	PAGE 6
HARDWARE ILLUSTRATION.....	PAGE 8
PART LIST / ILLUSTRATION.....	PAGE 10
ASSEMBLY INSTRUCTIONS.....	PAGE 12
EXPLODED VIEW.....	PAGE 28
CONTACT PAGE.....	PAGE 30

IMPORTANT SAFETY INSTRUCTIONS

Unpacking the Equipment

The BFFT10R is carefully tested and inspected before shipment. We have shipped the unit in two boxes that require assembly. Ask for assistance during the assembly process.

Carefully unpack the boxes and lay the pieces on the floor near the area where you plan to use the equipment.

When using exercise equipment, you should always take basic precautions, including the following:

- Read all instructions before using the BFFT10R. These instructions are written to ensure your safety and to protect the unit.
- **Do not remove any safety labels from the machine.**
- Do not allow children on or near the equipment.
- Use the equipment only for its intended purpose as described in this guide. Do not use accessory attachments that are not recommended by the manufacturer. Such attachments might cause injuries.
- Wear proper exercise clothing and shoes for your workout, no loose clothing.
- Keep hands, limbs, loose clothing, and long hair well out of the way of all moving parts.
- Use care when getting on or off the unit.
- Do not overexert yourself or work to exhaustion.
- If you feel any pain or abnormal symptoms, stop your workout immediately and consult your physician.
- Never operate unit when it has been dropped or damaged. Return the equipment to a service center for examination and repair.
- Never drop or insert objects into any opening in the equipment.
- Always check the unit before each use. Make sure that all fasteners are secure and in good working condition.
- Do not use the equipment outdoors or near water.

Personal Safety During Assembly

- It is strongly recommended that a qualified dealer assemble the equipment. Assistance is required.
- Before beginning assembly, please take the time to read the instructions thoroughly.
- Read each step in the assembly instructions and follow the steps in sequence. Do not skip ahead. If you skip ahead, you may learn later that you have to disassemble components and that you may have damaged the equipment.
- Assemble and operate the BFFT10R on a solid, level surface. Locate the unit a few feet from the walls or furniture to provide easy access.

The BFFT10R is designed for your enjoyment. By following these precautions and using common sense, you will have many safe and pleasurable hours of healthful exercise with your Best Fitness BFFT10R.

After assembly, you should check all functions to ensure correct operation. If you experience problems, first recheck the assembly instructions to locate any possible errors made during assembly. If you are unable to correct the problem, call the dealer from whom you purchased the machine or call 1-800-556-3113 for the dealer nearest you.

Obtaining Service

Please use this Owner's Manual to make sure that all parts have been included in your shipment. When ordering parts, you must use the part number and description from this Owner's Manual. Use only Best Fitness replacement parts when servicing this machine. Failure to do so will void your warranty and could result in personal injury.

For information about product operation or service, go to www.bestfitness.com or contact an authorized Best Fitness dealer or a Best Fitness factory-authorized service company or contact Best Fitness customer service at one of the following:

Toll Free: 1-800-556-3113
Phone: 1-708-427-3555
Fax: 1-708-427-3556
Hours: M-F 8:30-5:00 CST
E-Mail: service@bodysolid.com

Or write to: Best Fitness
Service Department
1900 S. Des Plaines Ave.
Forest Park, IL 60130 USA

Retain this Owner's Manual for future reference. Part numbers are required when ordering parts.

PREPARATION

Required Tools

The basic tools that you must obtain before assembling the BFFT10R include but are not limit to:

- Metric Wrench Set
- Adjustable Wrench
- Metric Allen Key Set
- Screwdriver (Standard/Phillips)

Installation Requirements

Follow the installation requirements when assembling the BFFT10R.

Set up the BFFT10R on a solid, flat surface. A smooth flat surface under the machine helps keep it level.

Provide ample space around the machine. Open space around the machine will allow for easier access.

For aesthetic purposes, insert all bolts in the same direction unless specified (in text or illustrations) to do so otherwise.

Leave room for adjustments. Tighten fasteners such as bolts, nuts, and screws so the unit is stable, but leave somewhat loose for adjustments. Do not fully tighten fasteners until instructed in the assembly steps to do so.

Fill out and mail the warranty card.

Ordering Replacement Parts

If you need to order replacement parts please be prepared to provide the following information when contacting us so that we can assist you better.

1. **Model Number**
2. **Place of Purchase**
3. **Serial Number (S/N)**
4. **Part# and Description**

Assembly Tips

Read all "Notes" on each page before beginning each step.

While you may be able to assemble the BFFT10R using the illustrations only, important safety notes and other tips are included in the text.

Some pieces may have extra holes that you will not use. Use only those holes indicated in the instructions and illustrations.

NOTE: With so many assembled parts, proper alignment and adjustment is critical. While tightening the nuts and bolts, be sure to leave room for adjustments.

NOTE: The bottles that are marked "Poison" is your touch up pain. Keep away from children.

CAUTION: Obtain assistance! If you feel like you can't assemble the BFFT10R by yourself then do not attempt to do so as this could result in injury. Review installation requirements before proceeding with the following steps.

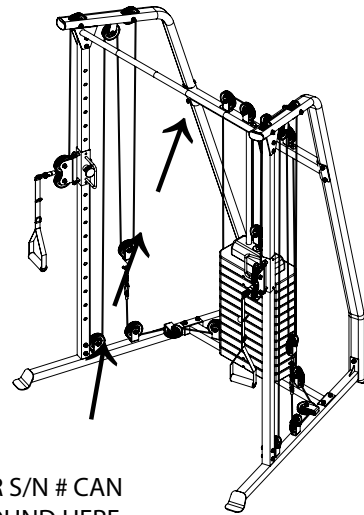

YOUR S/N # CAN
BE FOUND HERE

HARDWARE LIST

PART#	SIZE	DESCRIPTION	QUANTITY
1		PULL PIN	2 PCS.
2	25X12.5X10mm	BUSHING	4 PCS.
3	25X10.5X32mm	BUSHING	8 PCS.
4	7350mm	CABLE	1 PCS.
5	6740mm	CABLE	2 PCS.
6		STEEL CHAIN	2 PCS.
7		SNAP LINK	4 PCS.
8	90mm	PULLEY	25 PCS.
9		PLASTIC PLATE	1 PCS.
10	45X45mm	SQUARE END CAP	2 PCS.
11	40X80mm	OVAL END CAP	2 PCS.
12	25mm	END CAP	1 PCS.
13		SILICON NUBE	16 PCS.
14	56X96mm	EVA PAD	2 PCS.
15	86X45mm	EVA PAD	2 PCS.
16		RUBBER DONUT	2 PCS.
17		HANDLE STRAP	2 PCS.

HARDWARE LIST

PART#	SIZE	DESCRIPTION	QUANTITY
18	M12X175mm	HEX HEAD BOLT	2 PCS.
19	M10X40mm	HEX HEAD BOLT	21 PCS.
20	M10X60mm	HEX HEAD BOLT	12 PCS.
21	M10X70mm	HEX HEAD BOLT	4 PCS.
22	M10X100mm	HEX HEAD BOLT	4 PCS.
23	M6X8mm		3 PCS.
24	M8X10mm	SOCKET SCREW	6 PCS.
25	M6	ACORN CAPNUT	2 PCS.
26	M12	WASHER	4 PCS.
27	M10	WASHER	88 PCS.
28	M12	NYLON LOCK NUT	2 PCS.
29	M10	NYLON LOCK NUT	43 PCS.
30		TOP STACK	1 PCS.
31		BOTTOM STACK	12 PCS.
32		WEIGHT PLATE PIN	1 PCS.
33		PUSHNUT	1 PCS.
34		PIVOT AXLE	1 PCS.
35	M12	NUT	1 PCS.
36	38X12X2mm	WASHER	1 PCS.
37		CLEVIS PIN	2 PCS.
38		RETAINING RING	2 PCS.
41	M10X65mm	HEX HEAD BOLT	4 PCS

HARDWARE ILLUSTRATION

PART 18 - M12X175mm Hex Head Bolt, 2 PCS.

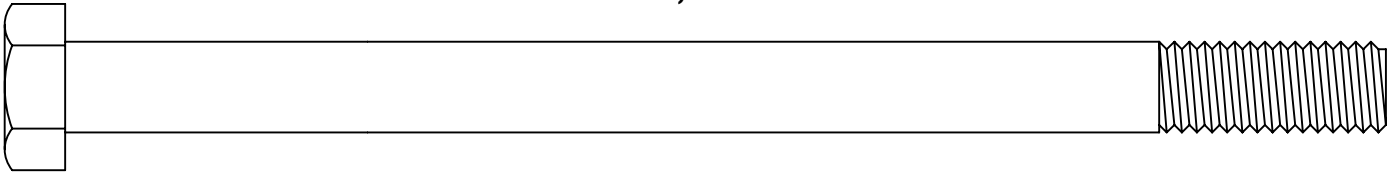

PART 19 - M10X45mm Hex Head Bolt, 21 PCS.

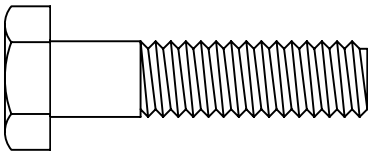

PART 20 - M10X60mm Hex Head Bolt, 16 PCS.

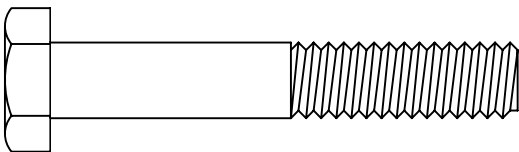

PART 21 - M10X70mm Hex Head Bolt, 4 PCS.

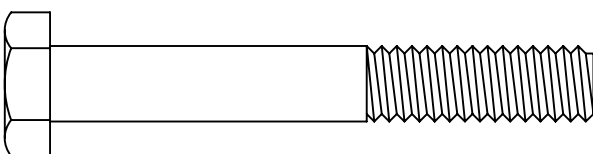

PART 22 - M10X100mm Hex Head Bolt, 4 PCS.

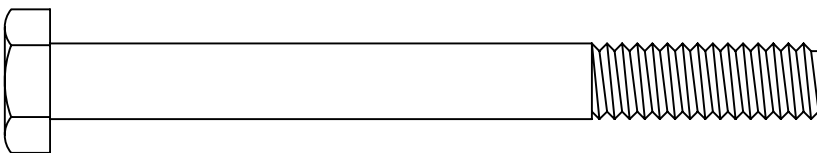

PART 23 - M6X8mm Screw, 3 PCS - Reserve for future usage.

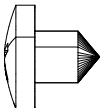

PART 26 - M12 Washer, 4 PCS.

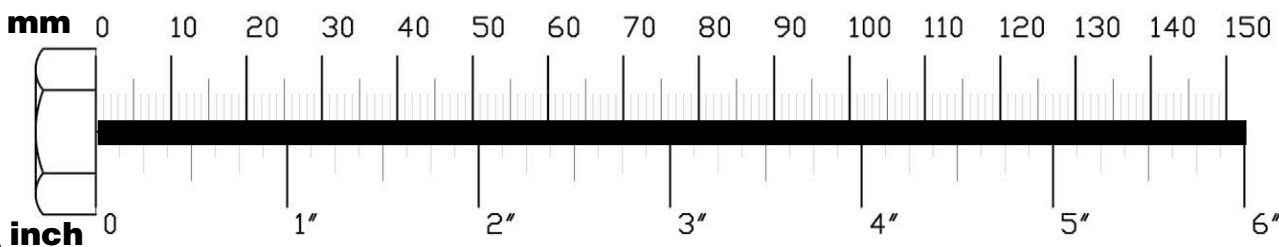
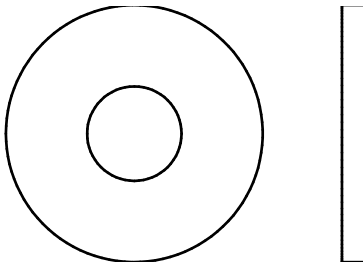

HARDWARE ILLUSTRATION

PART 27 - M10 Washer, 88 PCS.

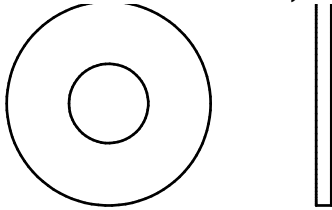

PART 28 - M12 Nylon Lock Nut, 2 PCS.



PART 29 - M10 Nylon Lock Nut, 43 PCS.

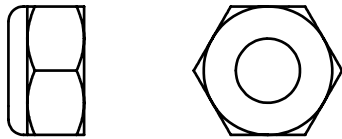

PART 33 - Push Nut, 1 PCS.

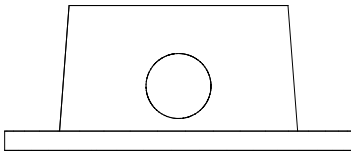

PART 34 - Pivot Axle, 1 PCS.



PART 35 - M12 Nut, 1 PCS.

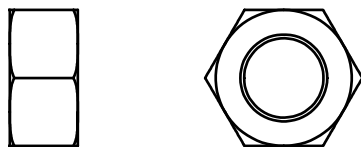

PART 36 - M12 Large Washer, 1 PCS.

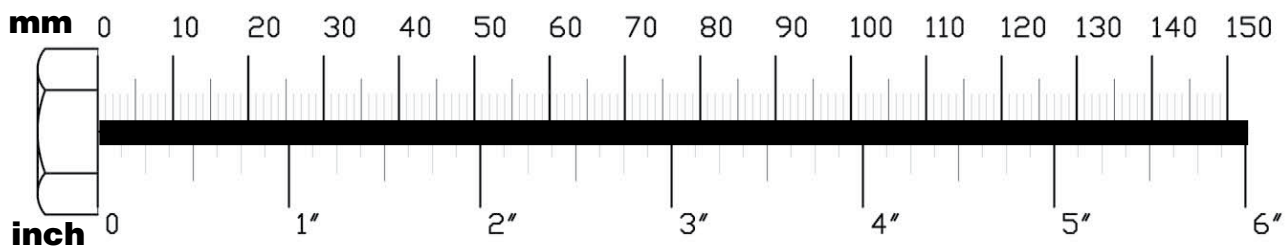
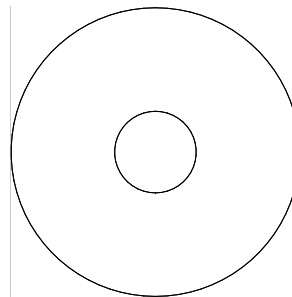

PART LIST

PART A - LEFT LOWER BEAM, 1 PCS.

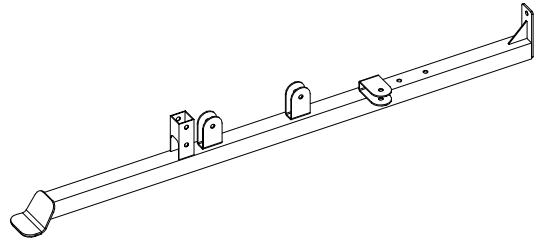

PART B - RIGHT LOWER BEAM, 1 PCS.

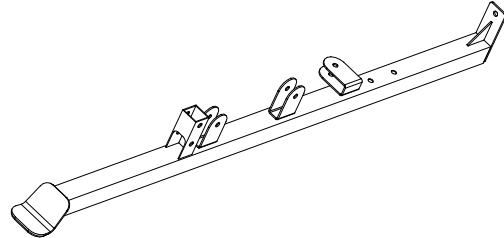

PART C - BASE FRAME, 1 PCS.

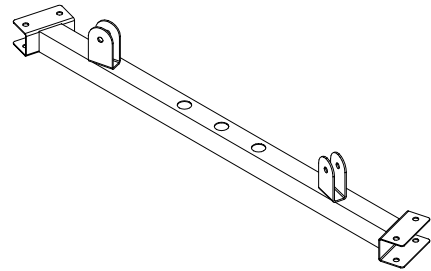

PART D - SELECTING UPRIGHT, 2 PCS.

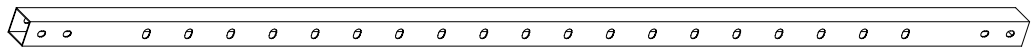

PART E - LEFT UPPER UPRIGHT, 1 PCS.

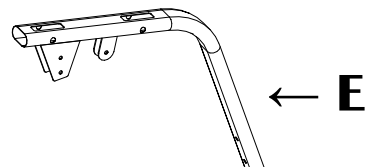

PART P - RIGHT UPPER UPRIGHT, 1 PCS.

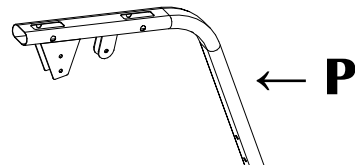

PART F - LOWER UPRIGHT, 2 PCS.

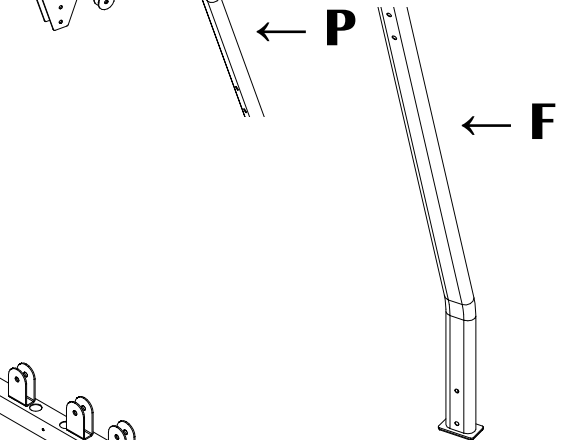

PART G - SUPPORT BEAM, 1 PCS.

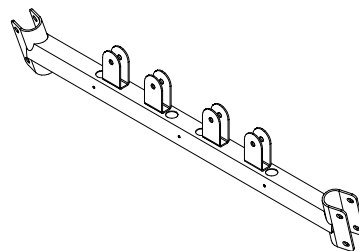

PART LIST

PART H - LAT BAR, 1 PCS.

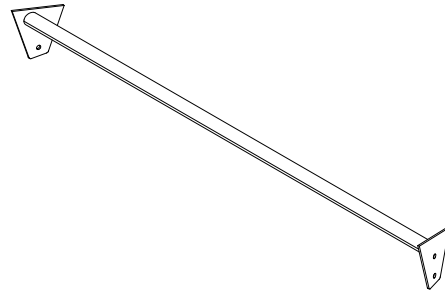

PART I - GUIDE ROD, 2 PCS.

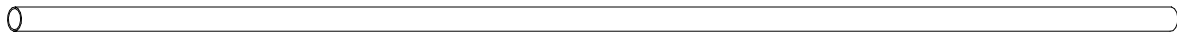

PART J - HANDLE ASSEMBLY, 2 PCS.

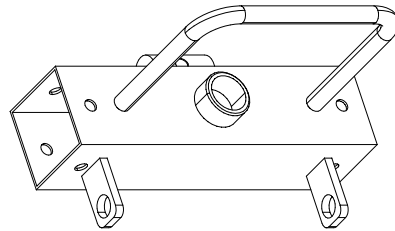

PART K - DOUBLE PULLEY, 2 PCS.

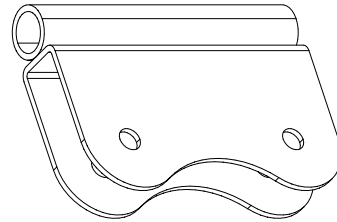

PART L - PULLEY HOLDER, 2 PCS.

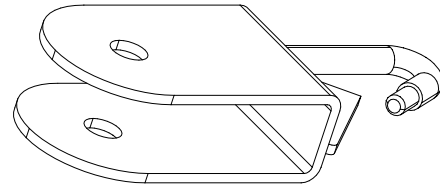

PART M - SINGLE PULLEY, 1 PCS.

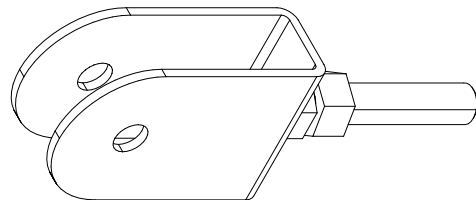

PART N - SELECTOR ROD, 1 PCS.



STEP**1**

Be careful to assemble all components in the sequence they are presented.

NOTE:

Finger tighten all hardware first in this step. Wrench tighten bolts at the end of this step, some components may be pre-assembled. Nylon lock nuts will not fully screw onto bolts, must wrench tighten.

1A. Attach Left Lower Beam (A) to Base Frame (C) using:

- 2 - (#20) M10X62mm Hex Head Bolt
- 4 - (#27) M10 Washer
- 2 - (#29) M10 Nylon Lock Nut

1B. Attach Right Lower Beam (B) to Base Frame (C) using:

- 2 - (#20) M10X62mm Hex Head Bolt
- 4 - (#27) M10 Washer
- 2 - (#29) M10 Nylon Lock Nut

Note: Bolt #20, M10X62mm, in this step needs to be bottom up as shown in the picture to the right.

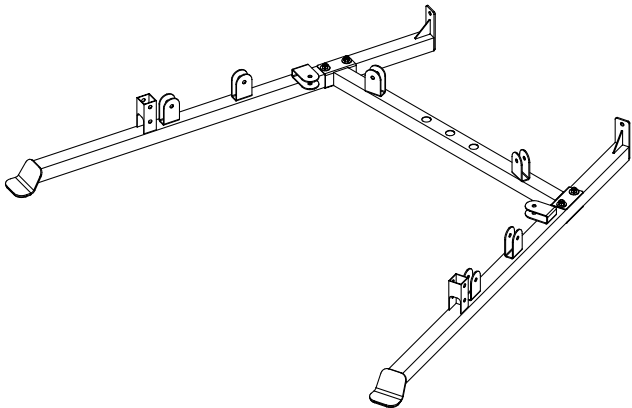

Above shows STEP 1 assembled and completed.

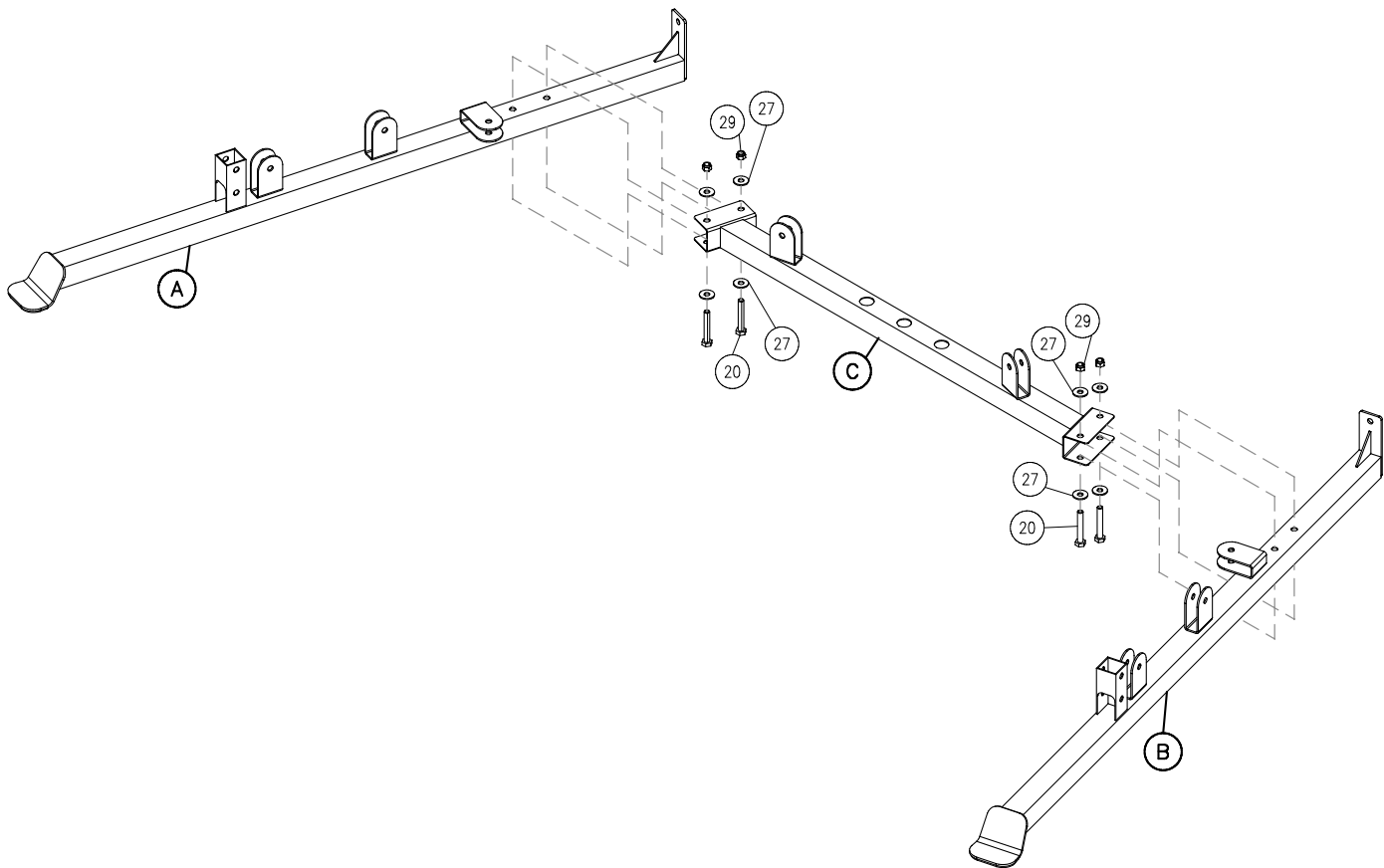

STEP**2**

Be careful to assemble all components in the sequence they are presented.

NOTE:

Finger tighten all hardware in this step. DO NOT wrench tighten until the end of Step 4, some components may be pre-assembled. Nylon lock nuts will not fully screw onto bolts, must wrench tighten.

2A. Attach Chrome Uprights (D) to Lower Beams (A & B) using:

- 4 - (#20) M10X60mm Hex Head Bolt
- 8 - (#27) M10 Washer
- 4 - (#29) M10 Nylon Lock Nut

2C. Slide a Handle Assembly (J) onto each Selecting Upright (D).**2D. Secure Lower Uprights (F) to Lower Beams (A & B) using:**

- 4 - (#20) M10X60mm Hex Head Bolt
- 6 - (#27) M10 Washer
- 2 - (#29) M10 Nylon Lock Nut

2E. Attach Upper Uprights (E & P) into Lower Uprights (F) and attach**Upper Uprights (E & P) to Chrome Uprights using:**

- 4 - (#21) M10X70mm Hex Head Bolt
- 8 - (#27) M10 Washer
- 4 - (#29) M10 Nylon Lock Nut

2F. Insert end caps into each top end opening of Upright (E & P) using:

- 2 - (#11) 40X80mm Oval End Cap

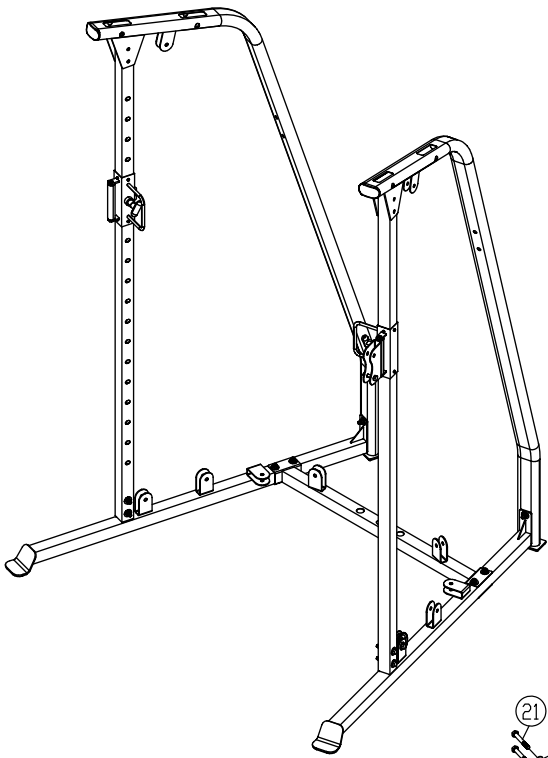

Above shows STEP 2 assembled and completed.

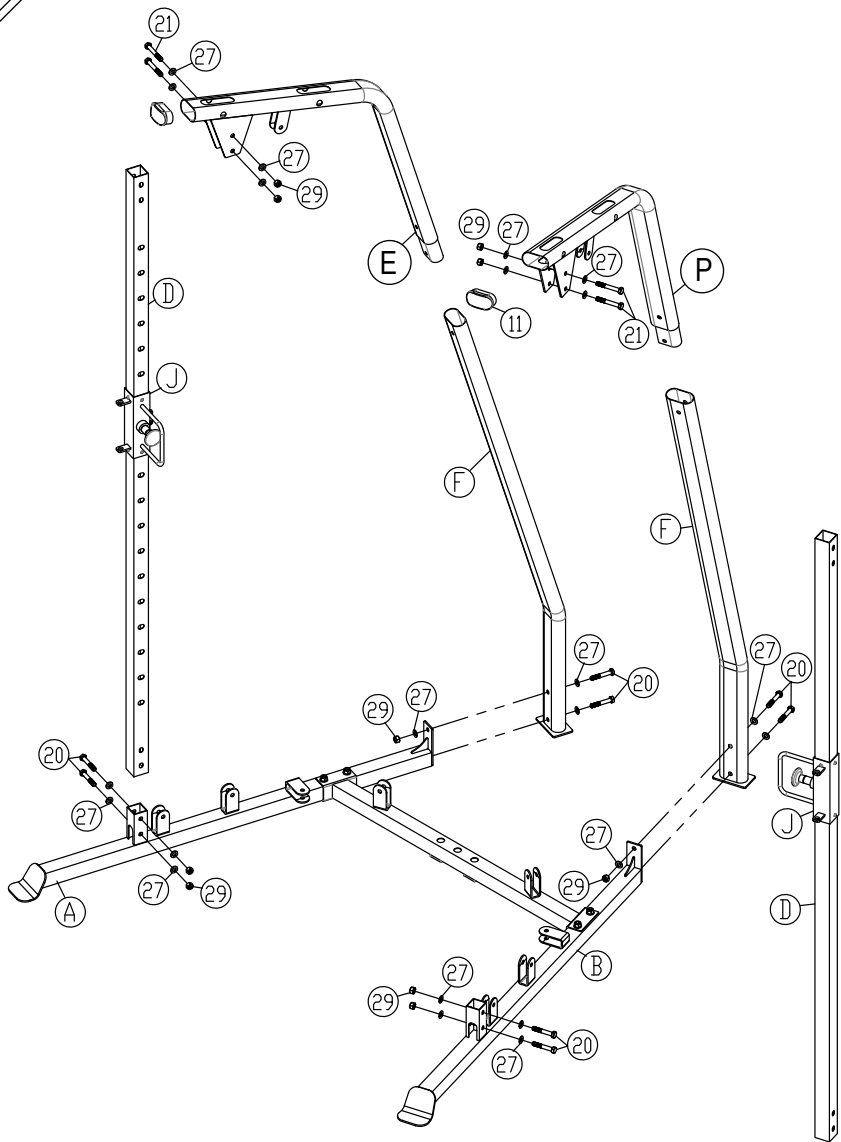

STEP**3**

Be careful to assemble all components in the sequence they are presented.

NOTE:

Finger tighten all hardware in this step. DO NOT wrench tighten until the end of Step 4, some components may be pre-assembled. Nylon lock nuts will not fully screw onto bolts, must wrench tighten.

- 3A. Insert each Guide Rod (Y) thru one 86X45mm Rubber Donut (#16) and into a circular opening of Base Frame (C).**
- 3B. Insert all Weight Plates (#31) onto Guide Rods (Y).**
- 3C. Insert Push Nut (#33) onto Selector Rod (N) and secure by sliding Pivot Axle (#34) thru the Push Nut (#33) and the first opening of Selector Rod (N).**
- 3D. Take the key ring end of the Weight Plate Pin (#32) and slide it onto the the threaded shaft of Single Pulley (M) and secure by screwing on a M12 Nut (#35).**
- 3E. While holding the Selector Rod, place the bottom end of Top Stack (#30) onto the Push Nut and the Pivot Axle.**
- 3F. Secure the Top Stack to the Selector Rod by sliding a M12 Large Washer (#36) onto the threaded shaft of Single Pulley (M) and screwing Single Pulley (M) into the internal threads of Selector Rod (M). Slide Top Stack onto Guide Rods (Y).
Note: Tighten the M12 Nut (#35) to better secure Single Pulley (M).**
- 3G. Insert Each Guide Rod (Y) into a circular opening of Support Beam (G), and attach Support Beam (G) to both Left and Right Upper Upright (E & P) using:
4 - (#41) M10X65mm Hex Head Bolt
8 - (#27) M10 Washer
4 - (#29) M10 Nylon Lock Nut**

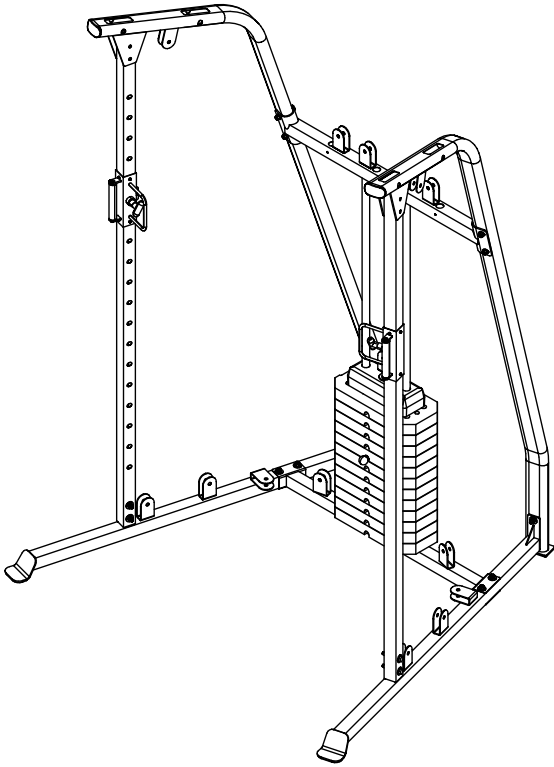

Above shows STEP 3 assembled and completed.

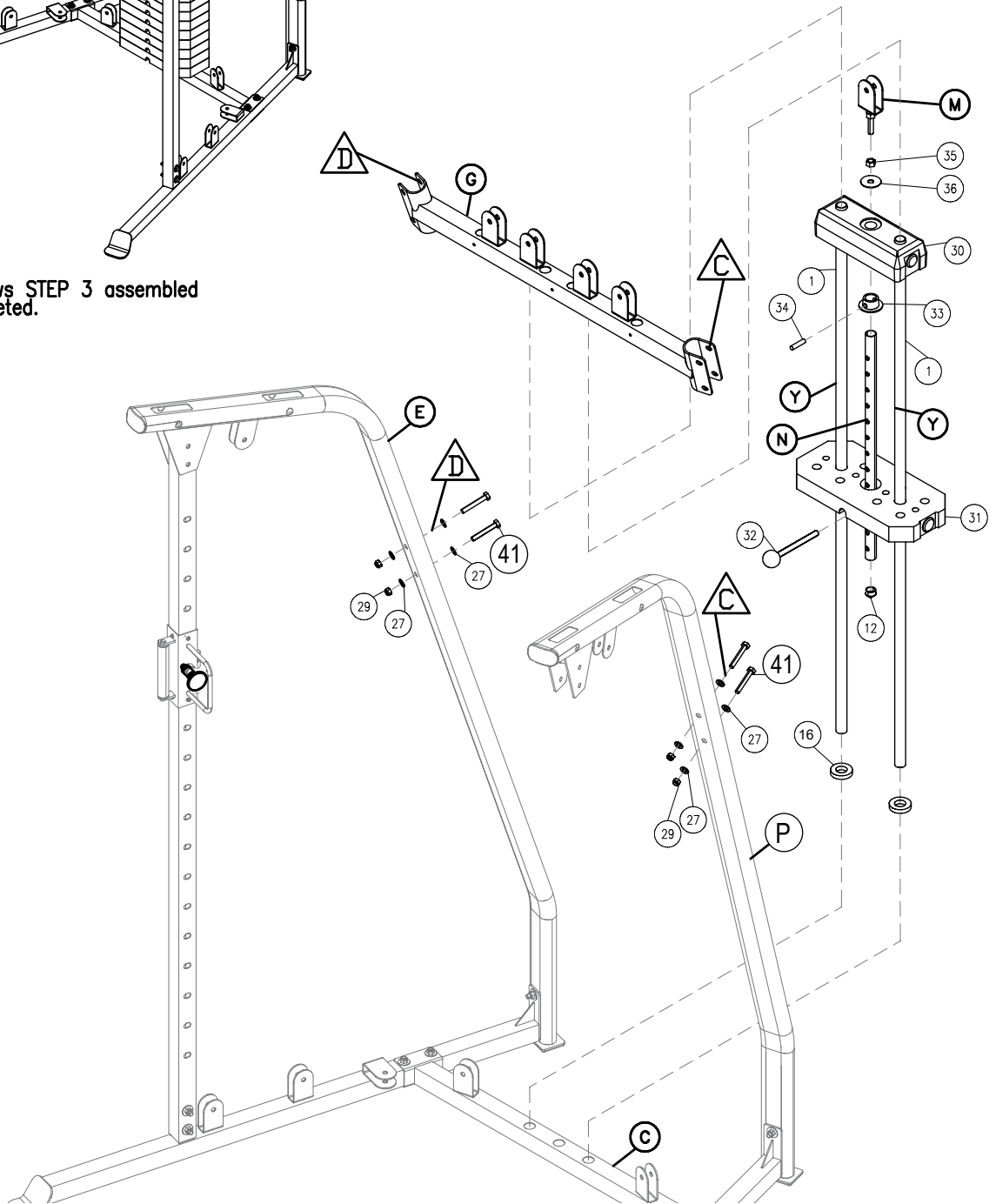

STEP**4**

Be careful to assemble all components in the sequence they are presented.

NOTE:

Finger tighten all hardware first. Wrench tighten all bolts at the end of this step, some components may be pre-assembled.

Nylon lock nuts will not fully screw onto bolts, must wrench tighten.

4A. Attach Lat Bar (H) to Left Upright (E) and Right Upright (P) using:

4 - (#21) M10X72mm Hex Head Bolt

8 - (#27) M10 Washer

4 - (#29) M10 Nylon Lock Nut

4B. Attach a Double Pulley (K) to a Handle Assembly (J) on both the left and right side using:

2 - (#18) M12X175mm Hex Head Bolt

4 - (#26) M12 Washer

2 - (#28) M12 Nylon Lock Nut

Note: Do not tighten down bolts to hard, make sure that the Double Pulley is able to swivel.

STEP

4

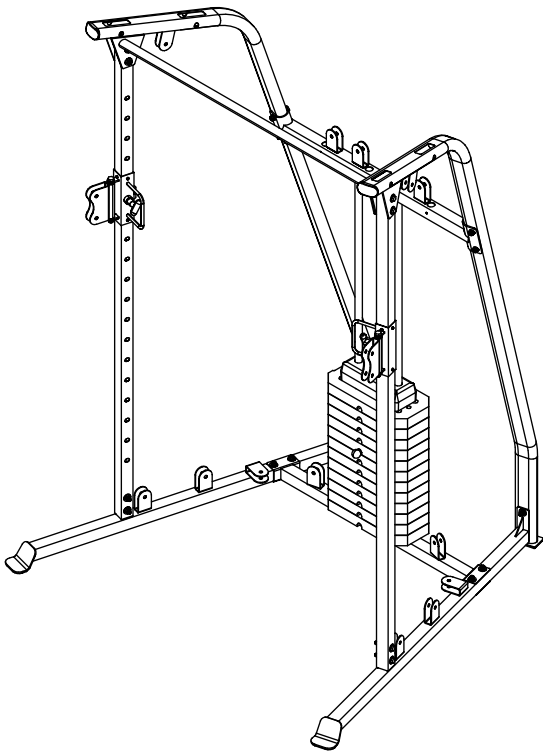

Above shows STEP 4 assembled and completed.

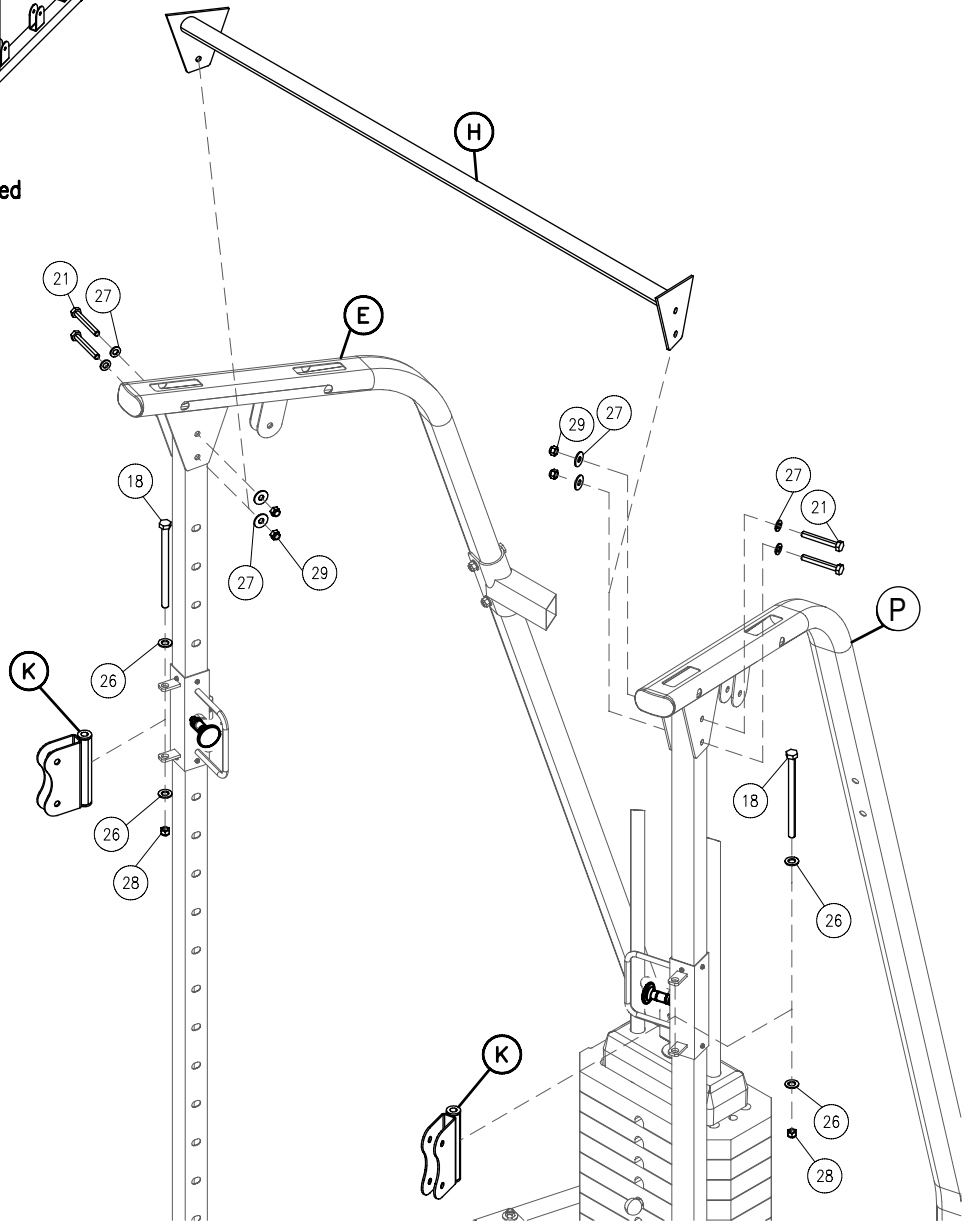

STEP**5**

Be careful to assemble all components in the sequence they are presented.

NOTE:

Finger tighten all hardware first. DO NOT wrench tighten until the end of step 8, some components may be pre-assembled.

Nylon lock nuts will not fully screw onto bolts, must wrench tighten.

5A. Attach two Pulleys to Double Pulley (K) using:

- 2 - (#19) M10X42mm Hex Head Bolt
- 4 - (#27) M10 Washer
- 2 - (#8) 90mm Pulley
- 2 - (#29) M10 Nylon Lock Nut

5B. Attach a Pulley to Pulley Holder (L), the inside holder of Left Upright (E), and the front holder of Left Lower Beam (A) using:

- 3 - (#19) M10X42mm Hex Head Bolt
- 6 - (#27) M10 Washer
- 3 - (#8) 90mm Pulley
- 3 - (#29) M10 Nylon Lock Nut

5C. Attach a Pulley to the front and rear top openings of Left Upright (E) using:

- 2 - (#22) M10X102mm Hex Head Bolt
- 4 - (#27) M10 Washer
- 4 - (#3) 25X10.5X32mm Bushing
- 2 - (#8) 90mm Pulley
- 2 - (#29) M10 Nylon Lock Nut

5D. Cable Routing: Use a 6740mm Cable (#5). First, route the non-clip end of the cable over pulley A1 and under then around pulley A2. Second, route the cable up and over pulley A3 then over and down pulley A4. Third, route the cable down and around pulley A5 then up and over pulley A6. Lastly, route the cable down and around pulley A7 and back up into the cable holder on Handle Assembly (J). Secure the cable just enough to hold by tightening the socket set screw (#24) that is pre-installed on Handle Assembly (J).

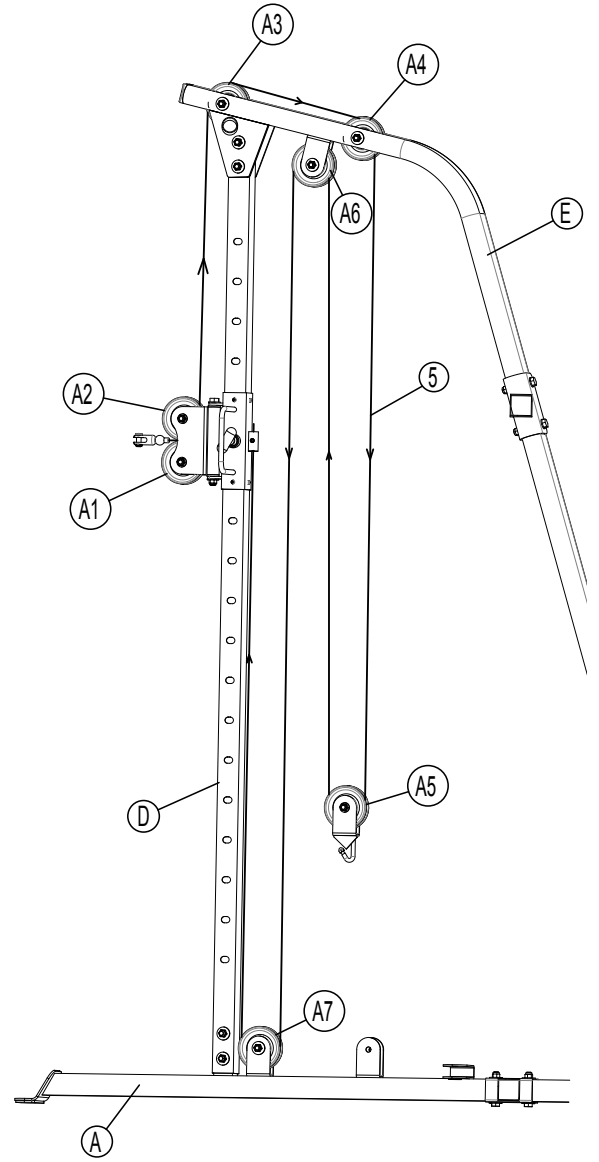
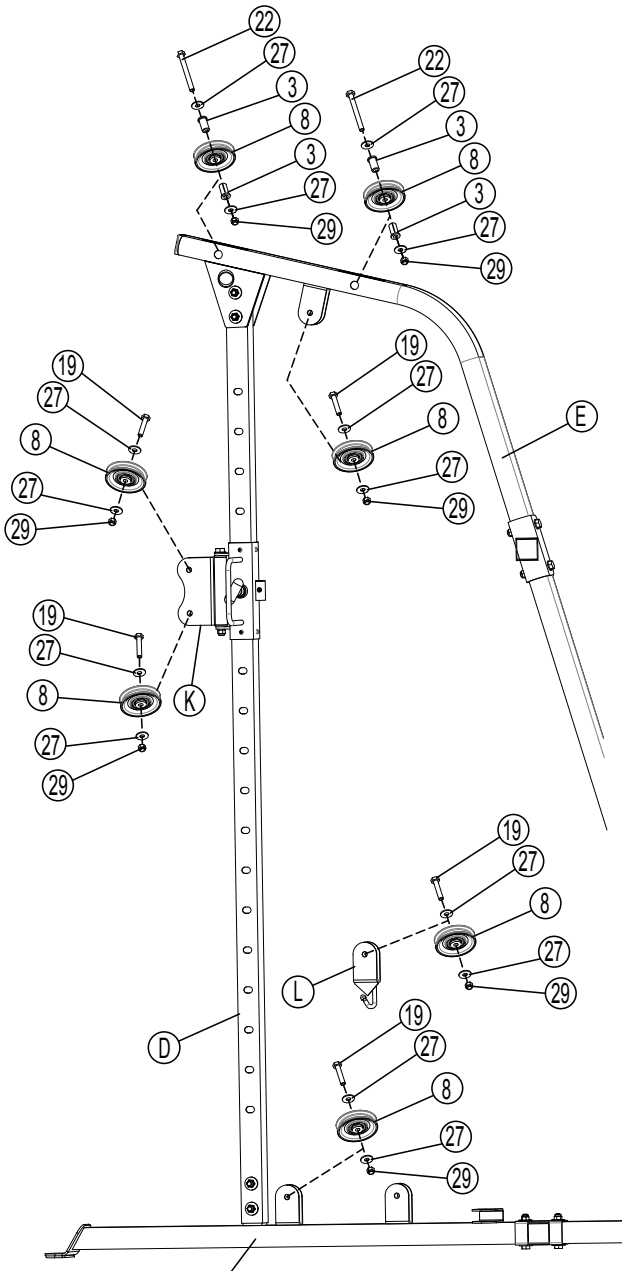

STEP**6**

Be careful to assemble all components in the sequence they are presented.

NOTE:

Finger tighten all hardware first. DO NOT wrench tighten until the end of step 8, some components may be pre-assembled.

Nylon lock nuts will not fully screw onto bolts, must wrench tighten.

6A. Attach two pulleys to Double Pulley (K) using:

- 2 - (#19) M10X42mm Hex Head Bolt
- 4 - (#27) M10 Washer
- 2 - (#8) 90mm Pulley
- 2 - (#29) M10 Nylon Lock Nut

6B. Attach a pulley to Pulley Holder (L), the inside holder of Right Upright (P), and the front holder of Right Lower Beam (B) using:

- 3 - (#19) M10X42mm Hex Head Bolt
- 6 - (#27) M10 Washer
- 3 - (#8) 90mm Pulley
- 3 - (#29) M10 Nylon Lock Nut

6C. Attach a pulley to the front and rear top openings of Right Upright (P) using:

- 2 - (#22) M10X102mm Hex Head Bolt
- 4 - (#27) M10 Washer
- 4 - (#3) 25X10.5X32mm Bushing
- 2 - (#8) 90mm Pulley
- 2 - (#29) M10 Nylon Lock Nut

6D. Cable Routing: Use a 6740mm Cable (#5). First, route the non-clip end of the cable over pulley B1 and under then around pulley B2. Second, route the cable up and over pulley B3 then over and down pulley B4. Third, route the cable down and around pulley B5 then up and over pulley B6. Lastly, route the cable down and around pulley B7 and back up into the cable holder on Handle Assembly (J). Secure the cable just enough to hold by tightening the socket set screw (#24) that is pre-installed on Handle Assembly (J).

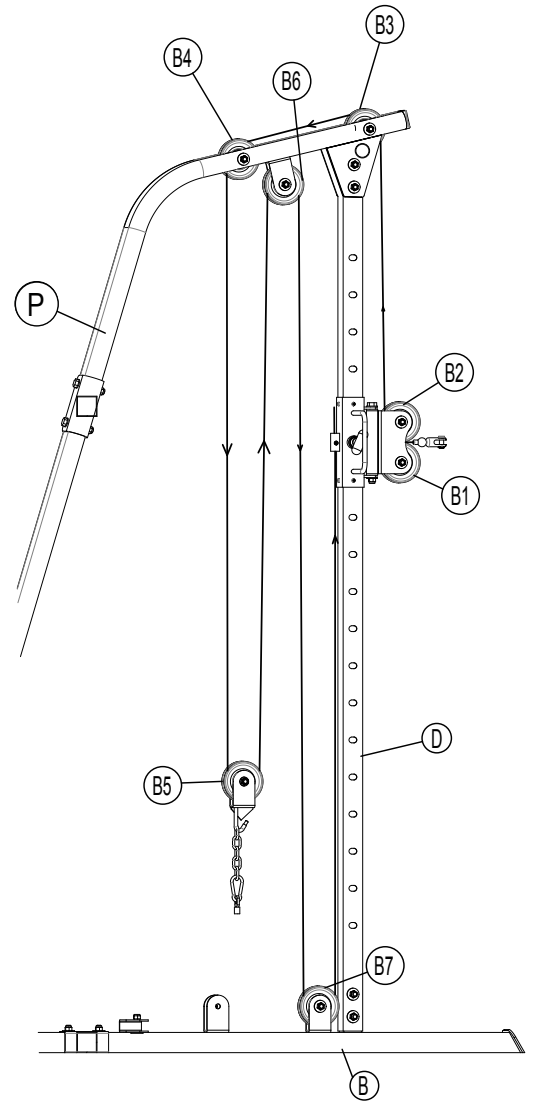
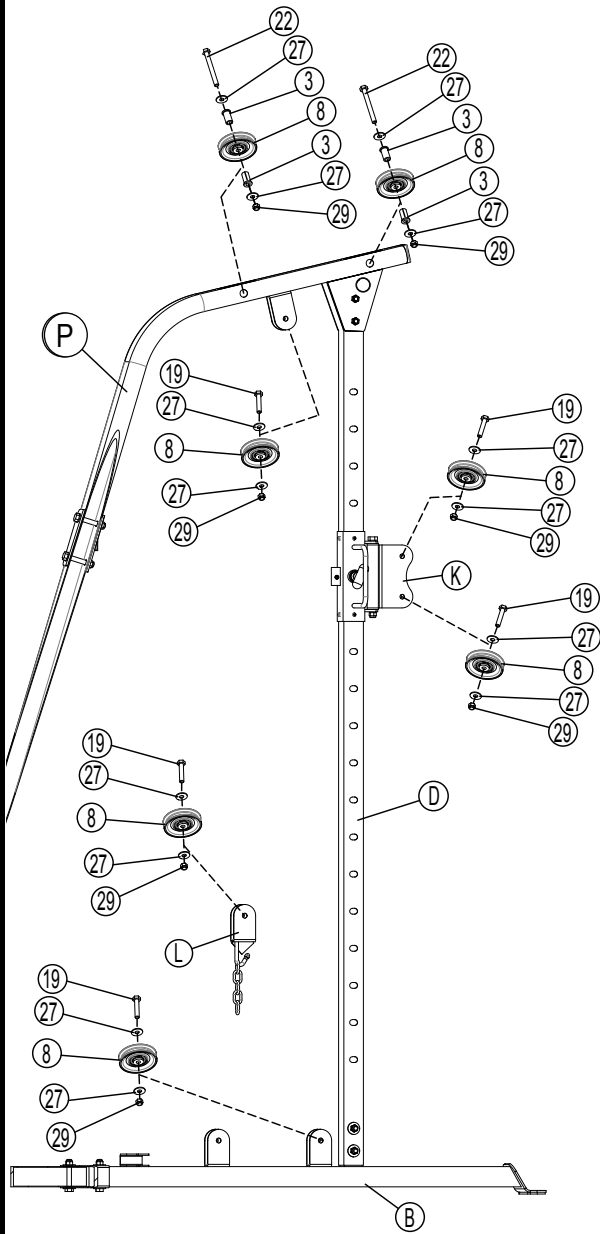

STEP**7**

Be careful to assemble all components in the sequence they are presented.

NOTE:

Finger tighten all hardware first. DO NOT wrench tighten all pulleys until the end of step 8, some components may be pre-assembled. Nylon lock nuts will not fully screw onto bolts, must wrench tighten.

NOTE: This step is to show the placement of the rest of your pulleys and the hardware you will need to install them. The pulleys in this step can be attached, however they will have to be removed and put back on while routing the final cable which can be found in the next step. To make things easier for you grab the parts and hardware you will need to complete this step and place them close to their attachment points.

7A. Attach four pulleys to the four pulley holders located on Support Beam (G) using:

- 4 - (#19) M10X42mm Hex Head Bolt
- 8 - (#27) M10 Washer
- 4 - (#8) 90mm Pulley
- 4 - (#29) M10 Nylon Lock Nut

7B. Attach two pulleys to the two pulley holders located on Base Frame (C), Left Lower Beam (A), and Right Lower Beam (B) using:

- 6 - (#19) M10X42mm Hex Head Bolt
- 12 - (#27) M10 Washer
- 6 - (#8) 90mm Pulley
- 6 - (#29) M10 Nylon Lock Nut

7C. Attach one pulley to Single Pulley (M) using:

- 4 - (#19) M10X42mm Hex Head Bolt
- 8 - (#27) M10 Washer
- 4 - (#8) 90mm Pulley
- 4 - (#29) M10 Nylon Lock Nut

7D. Attach one end of a three link chain to snap link and hook the other end of the chain onto each hook of Pulley Holder (L) and screw an acorn nut onto the end of each Pulley Holder (L) using:

- 2 - (#6) Steel Chain
- 2 - (#7) Snap Link
- 2 - (#25) M6 Acorn Cap Nut

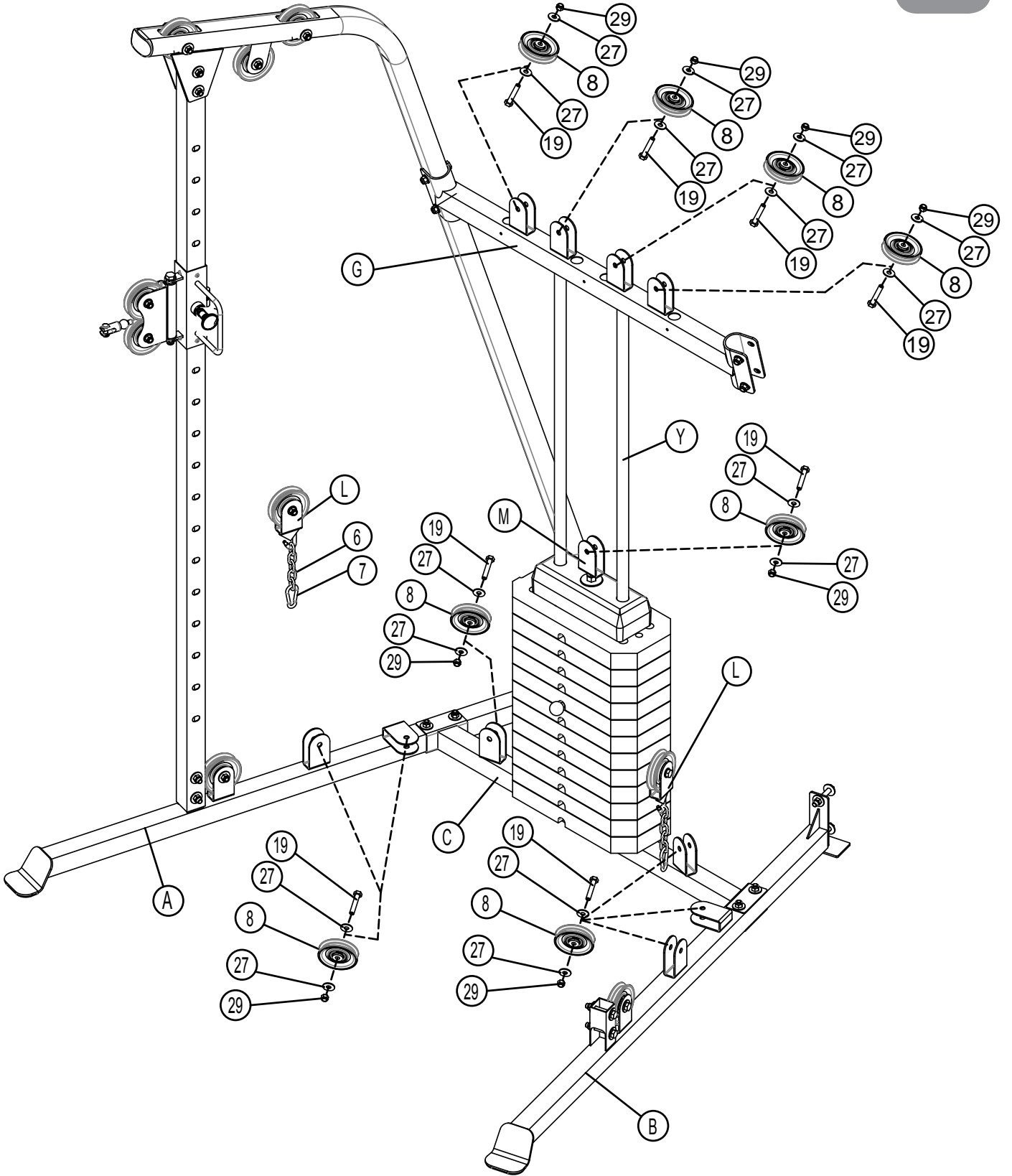

STEP**8**

Be careful to assemble all components in the sequence they are presented.

NOTE:

Finger tighten all hardware first. Wrench tighten all pulleys at the end of this step, some components may be pre-assembled.

Nylon lock nuts will not fully screw onto bolts, must wrench tighten.

NOTE: Only tighten the pulleys so that they are a little snug, over tightening them will cause them not to rotate properly.

Cable Routing: Use a 7350mm Cable (#4). First, hook one end of the cable onto the hook of Pulley Holder (L) that is on the left side above Lower Left Beam (A). Second, route the cable down, under, and around pulley C1, then over and around pulley C2, then under pulley C3 and up to pulley C4. Third, route the cable over pulley C4 and C5 and then down towards pulley C8. Fourth, route the cable around pulley C8, then back up and over pulley C6 and C7. Fifth, route the cable down and around pulley C9, then over and around pulley C10, then under pulley C11 and up to Pulley Holder (L) that is on the right side. Lastly, hook the other end of the cable onto the hook of Pulley Holder (L) that is on the right side.

***You have completed assembling your BFFT10R machine. The last thing you'll need to do is tighten the cables by stripping enough plastic coating on one side of the cable that is attached to one of the Handle Assemblies (J). Once there is no slack left, and the coating is stripped off secure the cable by tightening the socket set screw (#24) that is pre-installed on Handle Assembly (J) on both the left and right side. See pic. below.**

***To see the BFFT10R built live on video go to www.bodysolid.com**

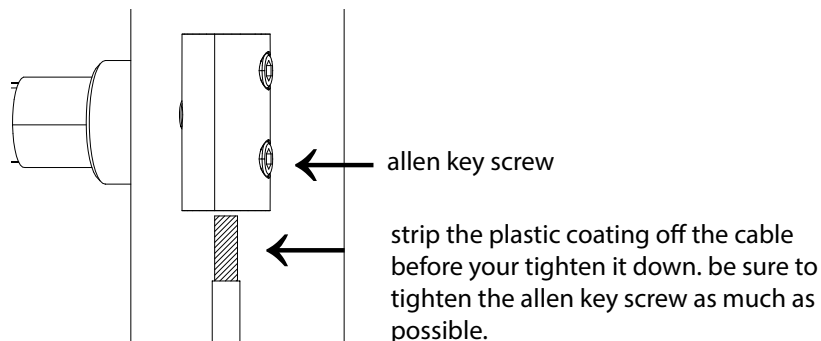

STEP

8

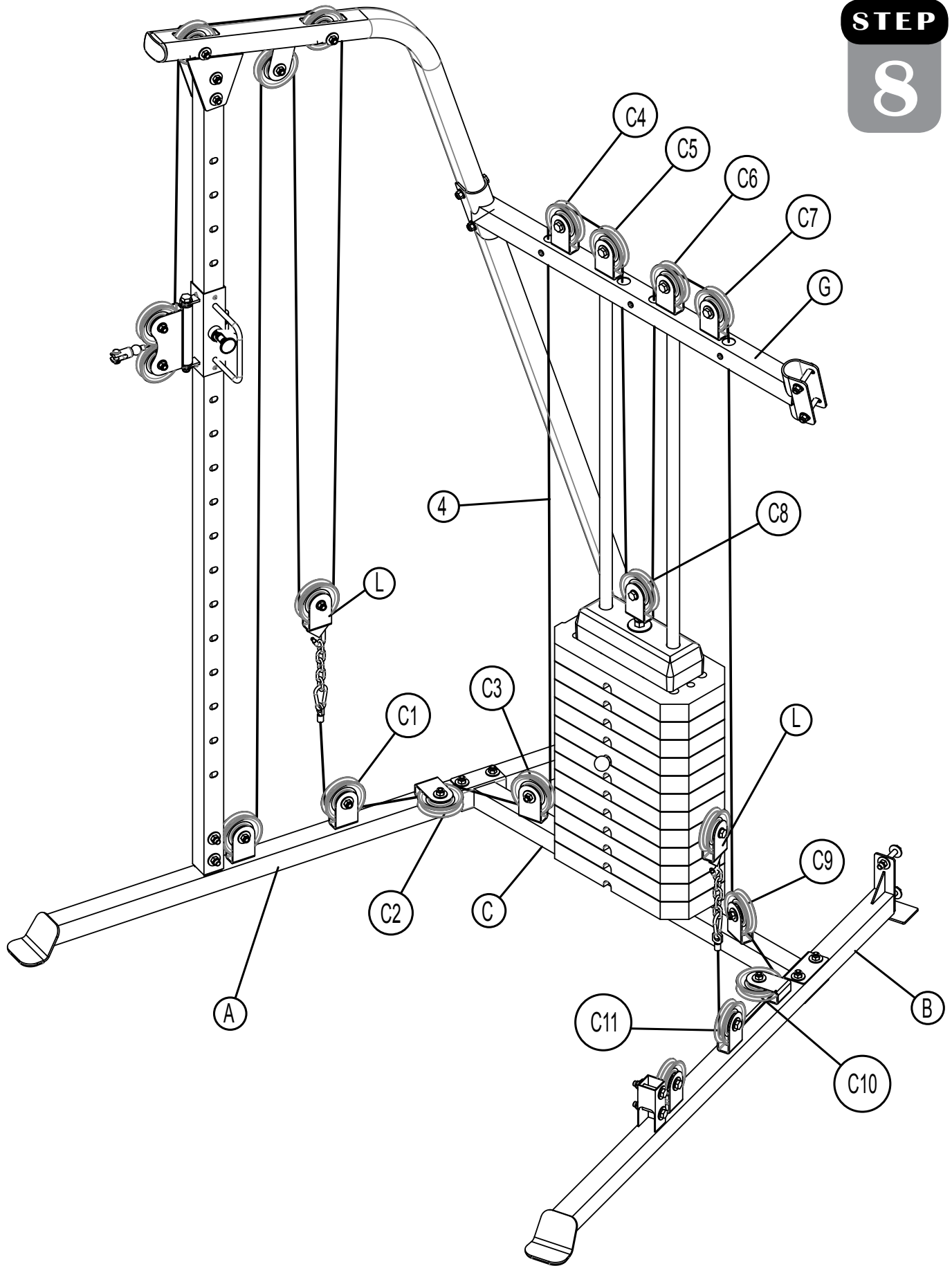

BFFT10R NOTES

