

Body-Solid®

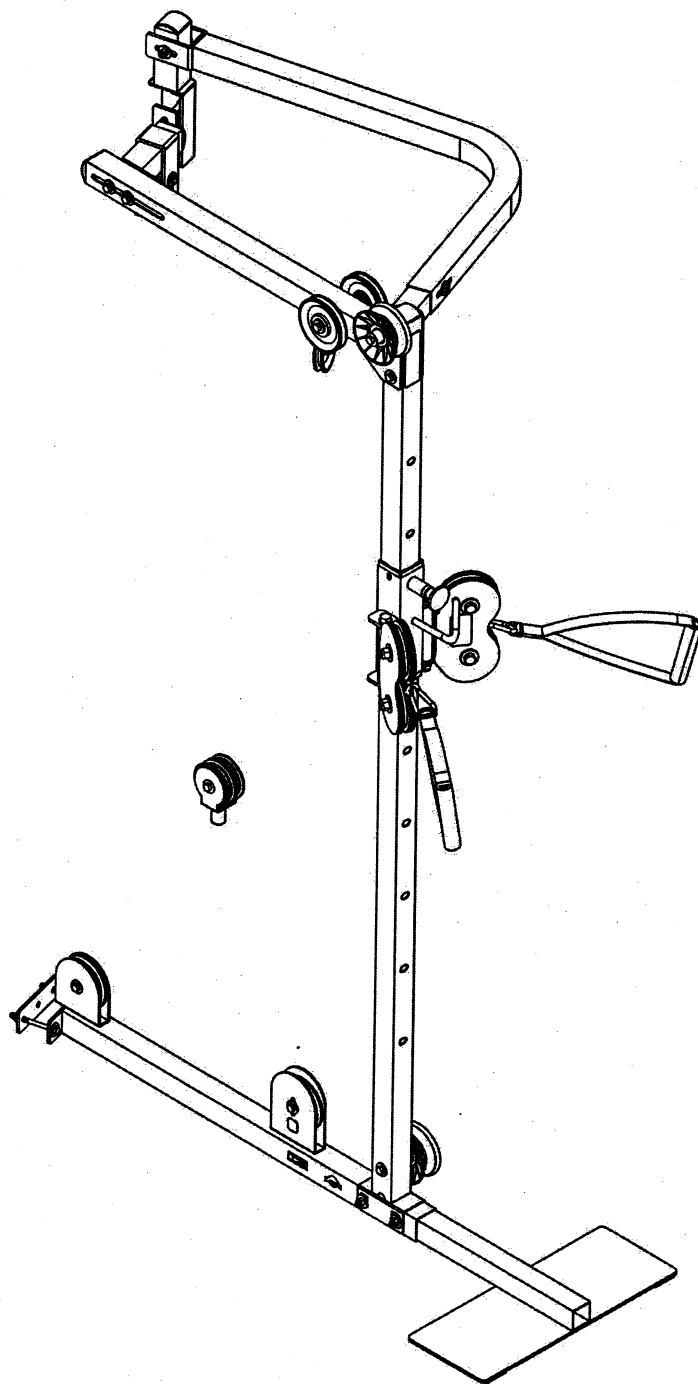

GCCA
(fits onto G2B, G3S, G5S, G6B, G10B)
ASSEMBLY INSTRUCTIONS

Before You Begin

Thank you for purchasing the Cable Column Attachment. This piece is part of the Body-Solid line of quality strength training machines, which let you target specific muscle groups to achieve better muscle tone and overall body conditioning.

This Attachment will fit onto the:

G2B
G3S
G5S
G6B
G10B

These instructions show the Cable Column Attachment being attached to only one gym. Because of the design of these gyms is similar, the Cable Column Attachment will fit.

When you attach the Cable Column Attachment, leave all nuts and bolts hand tight, until the last step is complete. Then go back and wrench tighten all nuts and bolts.

CAUTION: To set up this unit, you will need assistance.

You must review and follow the instructions in this Owner's Manual. If you do not assemble and use according to these guidelines, you could void the Body-Solid warranty.

CAUTION:
Obtain assistance.
Review the Installation Requirements before proceeding with the following steps.

Installation Requirements:

Set up on a solid, flat surface. A smooth, flat surface under the machine helps keep it level. A level machine has fewer malfunctions.

Provide ample space around the machine. Open space around the machine allows for easier access.

Unpacking the Equipment

Each piece is carefully tested and inspected before shipment. Body-Solid ships the unit in several pieces that require assembly. Ask for assistance during the assembly process.

Carefully unpack the boxes and lay the pieces on the floor near the area where you plan to use the equipment.

Be careful to assemble all components in the sequence presented in this guide.

If any items are missing, contact the dealer from whom you purchased the unit or call Body-Solid Customer Service at 1-800-833-1227.

NOTE: With so many assembled parts, proper alignment and adjustment is critical. While tightening the nuts and bolts, be sure to leave room for adjustments.

Insert all bolts in the same direction. For aesthetic purposes, insert all bolts in the same direction unless specified (in text or illustrations) to do otherwise.

Leave room for adjustments. Tighten fasteners such as bolts, nuts, and screws so the unit is stable, but leave room for adjustments. Do not fully tighten fasteners until instructed in the assembly steps to do so.

Fill out and mail warranty card.

Important Safety Instructions

Before beginning any fitness program, you should obtain a complete physical examination from your physician.

Il est conseillé de subir un examen médical complet avant d'entreprendre tout programme d'exercice.
Si vous avez des étourdissements ou des faiblesses, arrêtez les exercices immédiatement.

Antes de comenzar cualquier programa de ejercicios, deberías tener un examen físico con su doctor.

When using exercise equipment, you should always take basic precautions, including the following:

- Read all instructions before using the unit. These instructions are written to ensure your safety and to protect the unit.
- Do not allow children on or near the equipment.
- Use the equipment only for its intended purpose as described in this guide. Do not use accessory attachments that are not recommended by the manufacturer. Such attachments might cause injuries.
- Wear proper exercise clothing and shoes for your workout, no loose clothing.
- Use care when getting on or off the unit.
- Do not overexert yourself or work to exhaustion.
- If you feel any pain or abnormal symptoms, stop your workout immediately and consult your physician.
- Never operate unit when it has been dropped or damaged. Return the equipment to a service center for examination and repair.
- Never drop or insert objects into any opening in the equipment.
- Always check the unit before each use. Make sure that all fasteners are secure and in good working condition.
- Do not use the equipment outdoors or near water.

Personal Safety During Assembly

If possible have a qualified dealer assemble the equipment.

- Before beginning assembly, please take the time to read the instructions thoroughly.
- Read each step in the assembly instructions and follow the steps in sequence. Do not skip ahead. If you skip ahead, you may learn later that you have to disassemble components and that you may have damaged the equipment.
- Assemble and operate on a solid, level surface. Locate the unit a few feet from the walls or furniture to provide easy access.

This unit is designed for your enjoyment. By following these precautions and using common sense, you will have many safe and pleasurable hours of healthful exercise with your Body-Solid bench.

After assembly, you should check all functions to ensure correct operation. If you experience problems, first recheck the assembly instructions to locate any possible errors made during assembly. If you are unable to correct the problem, call the dealer from whom you purchased the machine or call 1-800-833-1227 for the dealer nearest you.

Obtaining Service

Please use this Owner's Manual to make sure that all parts have been included in your shipment. When ordering parts, you must use the key number, part number, and description from this Owner's Manual. Use only Body-Solid replacement parts when servicing this machine. Failure to do so will void your warranty and could result in personal injury.

For information about product operation or service, check out the official Body-Solid website at:
www.bodysolid.com

or contact an authorized Body-Solid dealer or a Body-Solid factory-authorized service company or contact Body-Solid customer service at one of the following:

Toll Free: 1-800-556-3113
Phone: 1-708-427-3555 ext. 5
Fax: 1-708-427-3556
E-mail: service@bodysolid.com

Or write to: Body-Solid, Inc.
Service Department
1900 S. Des Plaines Ave.
Forest Park, IL 60130 USA

Retain this Owner's Manual for future reference. Part numbers are required when ordering parts.

Safety Guidelines

Successful resistance training programs have one prominent feature in common...safety. Resistance training has some inherent dangers, as do all physical activities. The chance of injury can be greatly reduced or completely removed by using correct lifting techniques, proper breathing, maintaining equipment in good working condition, and by wearing the appropriate clothing.

- 1. It is highly recommended that you consult your physician before beginning any exercise program. This is especially important for individuals over the age of 35, or persons with pre-existing health problems.**
- 2. Always warm up before starting a workout. Try to do a total body warm up before you start. It is especially important to warm up the specific muscle groups you are going to be using. This can be as simple as performing a warm up set of high repetitions and light weight for each exercise.**
- 3. Use proper form. Focus on only working the muscle groups intended for the exercise you are doing. If there is strain elsewhere, you may need to re-evaluate the amount of weight that is involved with the lift. Keeping proper form also includes maintaining control through an entire range of motion.**
- 4. Breathe properly. Inhale during the eccentric phase of the exercise, and exhale during the lifting, or concentric phase. Never hold your breath during any part of an exercise.**
- 5. Always wear the appropriate clothing and shoes when exercising. Wearing comfortable athletic shoes with good support and suitable, breathable clothing will reduce the risk of injury.**
- 6. Maintaining equipment in proper operating condition is of utmost importance for a safe resistance training program. Pulleys and cables should be checked for wear frequently and replaced as needed. Equipment should be lubricated as indicated by the manufacturer.**
- 7. Read and study all warning labels on this machine. It is absolutely necessary that you familiarize yourself and all others with the proper operation of this machine prior to use.**
- 8. Keep hands, limbs, loose clothing and long hair well out of the way of all moving parts.**
- 9. Do not attempt to lift more weight than you can control safely.**
- 10. Inspect the machine daily for loose or worn parts. If a problem is found do not allow the machine to be used until all parts are tightened or worn or defective parts are repaired or replaced.**

Assembly Instructions

Professional installers are highly recommended!

However, if you acquire the appropriate tools, obtain assistance, and follow the assembly steps sequentially, the process will take time, but is fairly easy.

Required Tools:

9/16" Open-End Wrench
11/16" Open-End Wrench
3/4" Open-End Wrench
13/16" Open-End Wrench

Assembly Tips:

Read all "Notes" on each page before beginning each step.

While you may be able to assemble this unit using the illustrations only, important safety notes and other tips are included in the text.

Some pieces may have extra holes that you will not use. Use only those holes indicated in the instructions and illustrations.

NOTE: To find out the length of a particular bolt, measure its shank (the long, narrow part beneath the head). Refer to the following diagram:

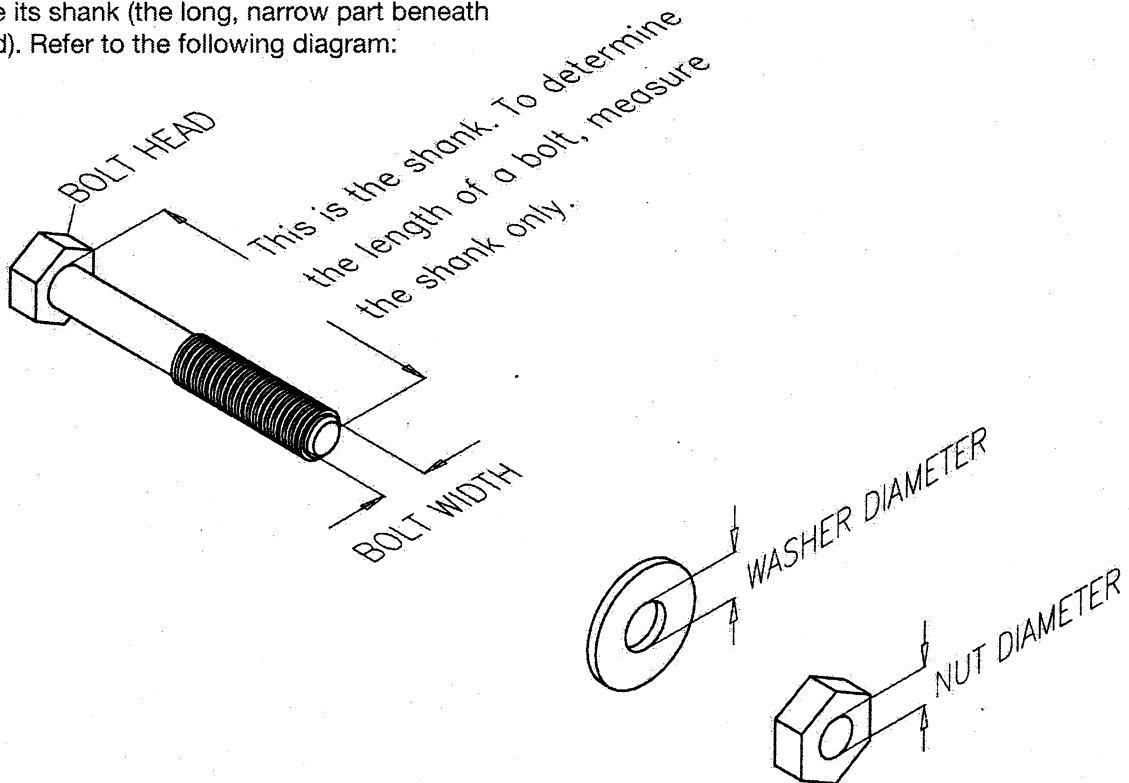

Do not fully tighten bolts until instructed to do so.

Note: After assembly, you should check all functions to ensure correct operation. If you experience problems, first recheck the assembly instructions to locate any possible errors made during assembly. If you are unable to correct the problem, call the dealer from whom you purchased the machine or call 1-800-556-3113 for the dealer nearest you.

STEP**1**

Be careful to assemble all components in the sequence they are presented.

NOTE:

Finger tighten all hardware in this step. Do Not wrench tighten until the end of step 6.

***NOTE:**

Use bolt 16 (3/8" x 3") for gyms G2B, G3S, G5S, and G6B.

- A. Attach Main Base Frame (A) and Flat Plate (37) to the Main Support Frame of your gym as shown using:
- Two 16 (3/8" x 3" hex head bolt)***
 - Four 21 (3/8" washer)**
 - Two 31 (3/8" nylon lock nut)**

***NOTE:**

Use bolt 36 (3/8" x 4") for gym G10B.

Attach Main Base Frame (A) to the Main Support Frame of your gym using:

- Two 36 (3/8" x 4" hex head bolt)***
- Four 21 (3/8" washer)**
- Two 31 (3/8" nylon lock nut)**

- B. Slide Foot Plate (B) into Main Base Frame (A) and line up the holes.
- C. Attach Chrome Upright (C) and Foot Plate (B) to Main Base Frame (A) using:
- Two 16 (3/8" x 3" hex head bolt)**
 - Four 21 (3/8" washer)**
 - Two 31 (3/8" nylon lock nut)**

***NOTE:**

This Socket Head Bolt (11) might be pre-installed.

- D. Attach Convex End Cap (33) to the Foot Plate (B), and Convex End Cap (1) the top of Chrome Upright (C) as shown.
Insert Socket Head Bolt (11)* into the Chrome Upright (C) as shown.

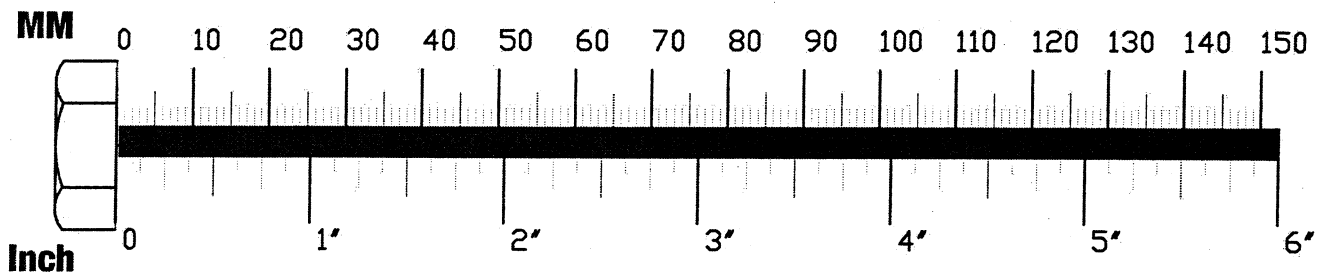

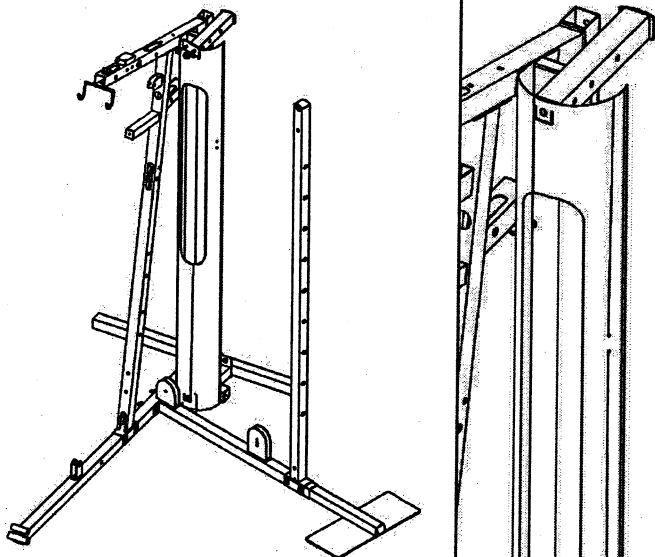

Above shows STEP 1 assembled and completed.

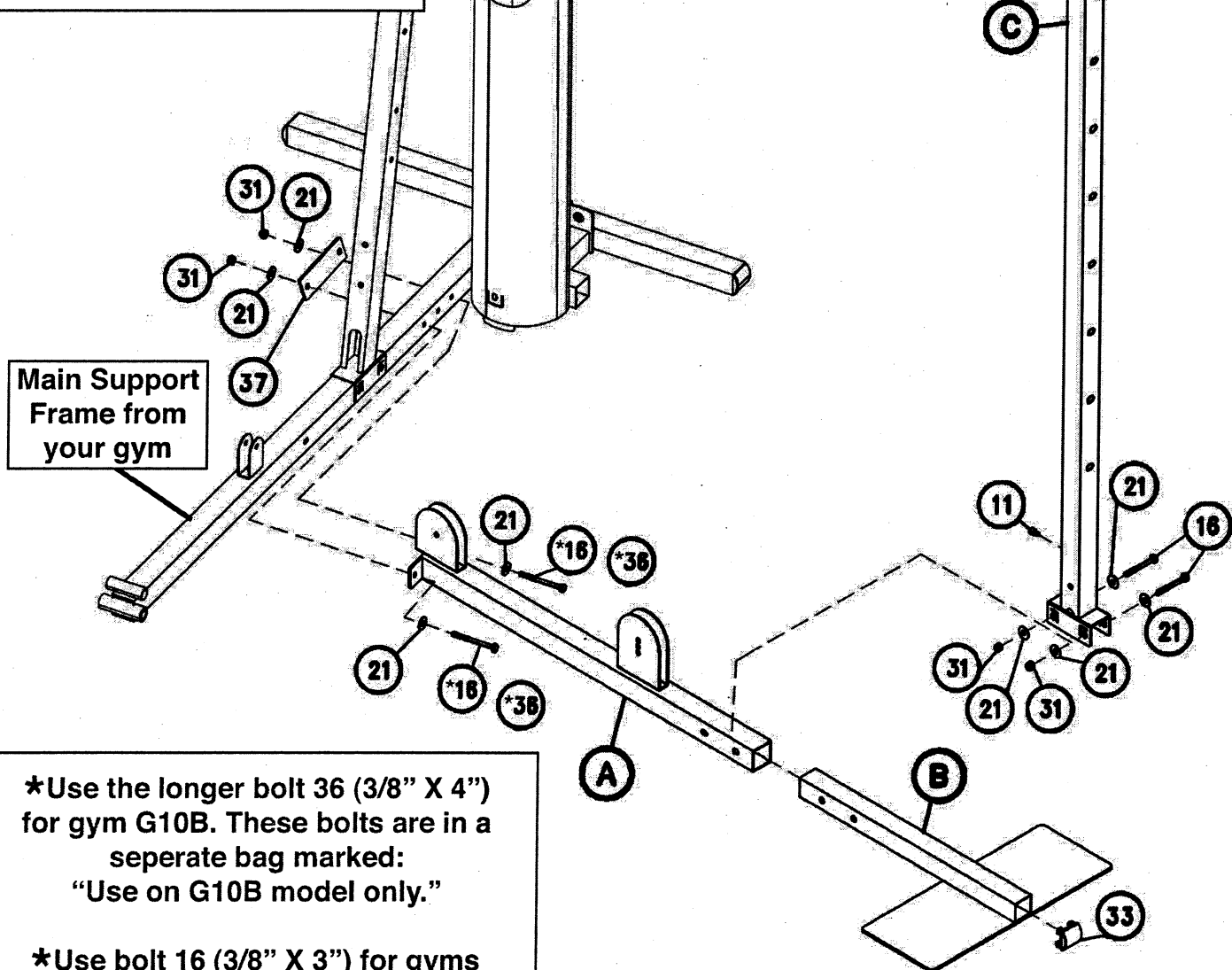

*Use the longer bolt 36 (3/8" X 4") for gym G10B. These bolts are in a separate bag marked: "Use on G10B model only."

*Use bolt 16 (3/8" X 3") for gyms G2B, G3S, G5S, and G6B. These bolts are in a separate bag marked: "Use on G2B, G3S, G5S, and G6B model only."

Be careful to assemble all components in the sequence they are presented.

NOTE:

Finger tighten all hardware in this step. Do Not wrench tighten until the end of step 6.

- A. Insert two Nylon Bushings (2) into Adjustable Pulley Holder (D) as shown. Slide Adjustable Pulley Holder (D) onto Chrome Upright (C) and hold in place with Flat Pop Pin (3).
- B. Attach two Double Pulley Pivots (E) and (F) to the Adjustable Pulley Holder (D) using:
Two 12 (1/2" x 6 1/2" hex head bolt)
Four 34 (1/2" washer 1" O.D.)
Two 30 (1/2" nylon lock nut)
- C. Attach Convex End Cap (1) onto Top Frame Attachment (G), slide Top Frame Attachment (G) into Top Frame Clamp (H). Clamp Top Frame Clamp (H)* to the top of your gym above the weight stack as shown using:
One 16 (3/8" x 3" hex head bolt)
Two 21 (3/8" washer)
One 31 (3/8" nylon lock nut)

***NOTE:**

There are no holes to bolt the Top Frame Clamp (H) onto your unit, so clamp this piece around the frame.

- D. Attach Top Frame (J) to Top Frame Attachment (G) using:
Two 15 (3/8" x 2 1/2" hex head bolt)
Two 22 (3/8" spring lock washer)
Two 21 (3/8" washer)
- E. Attach Top Frame (J) and Plastic Pulley Wide (6) to Chrome Upright (C) using:
One 16 (3/8" x 3" hex head bolt)
One 17 (3/8" x 5" hex head bolt)
Four 21 (3/8" washer)
Two 31 (3/8" nylon lock nut)
 Attach Convex End Cap (1) onto Top Frame (J) as shown.

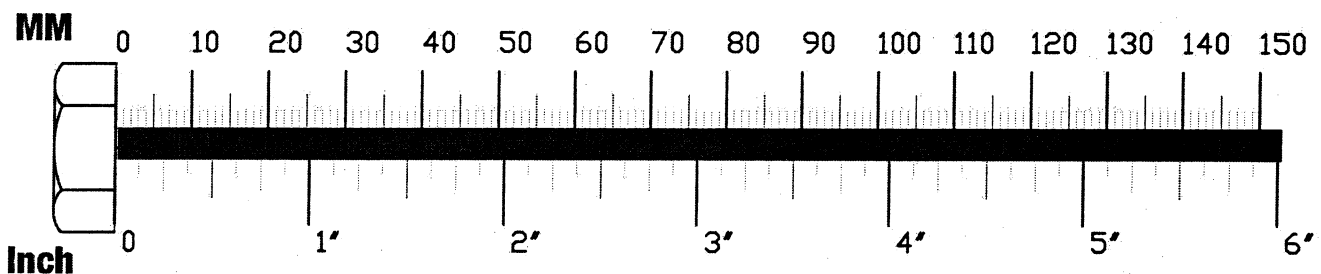

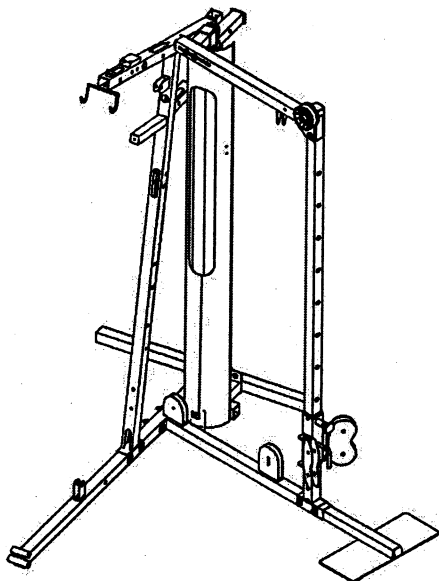

Above shows STEP 2 assembled and completed.

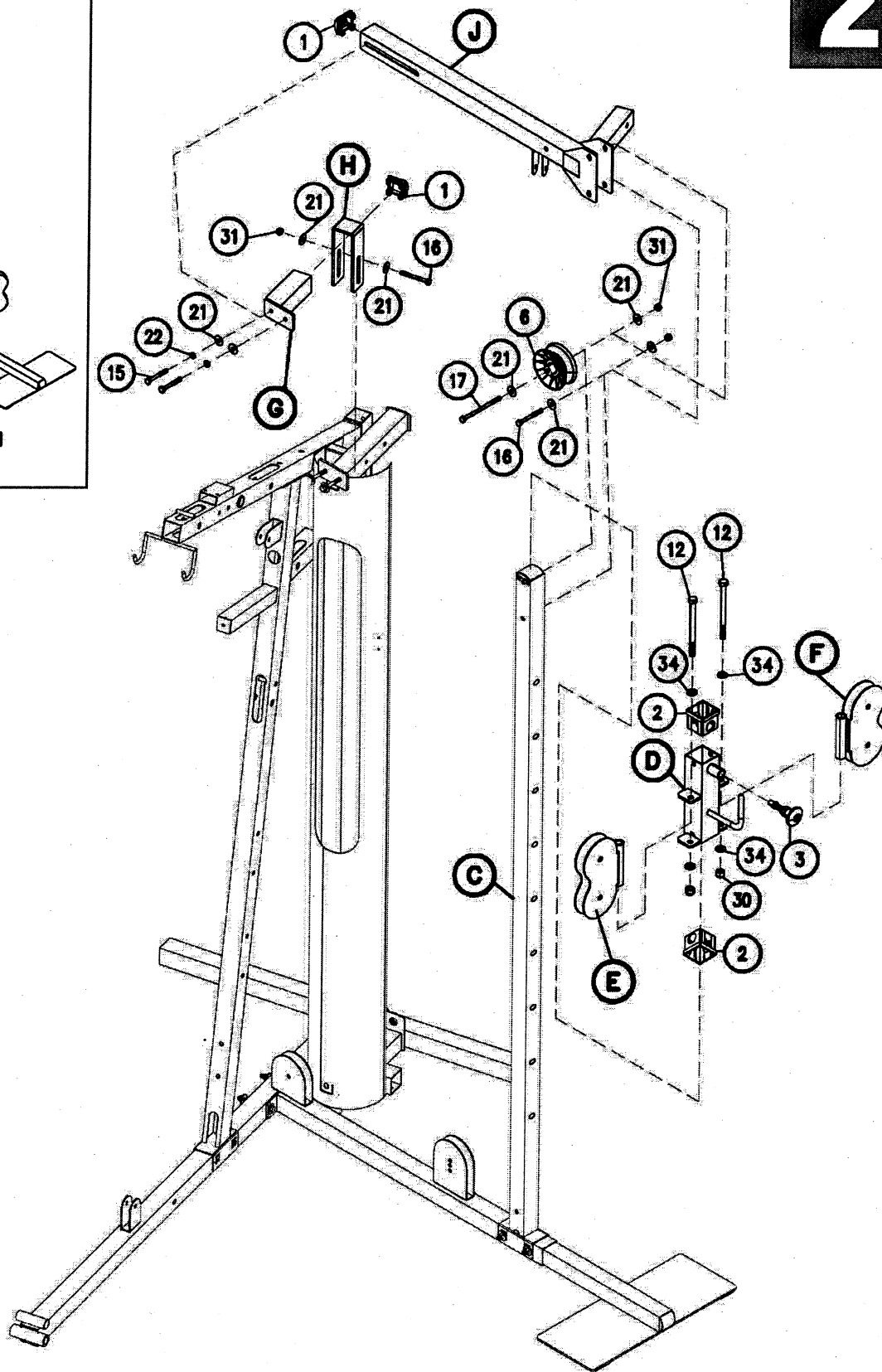

Be careful to assemble all components in the sequence they are presented.

NOTE:

Finger tighten all hardware in this step. Do Not wrench tighten until the end of step 6.

- A. Remove the Curved End Cap, Metal Plate, and hardware from the top of your gym. Attach Top Support Attachment (K) to the top of your gym as shown using:
Two 16 (3/8" x 3" hex head bolt)
Three 21 (3/8" washer)
One 31 (3/8" nylon lock nut)
- B. Slide the open end of Top Frame Support (L) around Top Support Attachment (K). Attach Top Frame Support (L) to Top Frame (J) as shown using:
One 15 (3/8" x 2 1/2" hex head bolt)
Two 21 (3/8" washer)
One 31 (3/8" nylon lock nut)
 Attach Top Frame Support (L) to Top Support Attachment (K) as shown using:
One 16 (3/8" x 3" hex head bolt)
Two 21 (3/8" washer)
One 31 (3/8" nylon lock nut)
- C. Attach two Plastic Pulley (5) to Top Frame (J) as shown using:
One 18 (3/8" x 5 3/4" hex head bolt)
Two 21 (3/8" washer)
Two 8 (spacer)
One 31 (3/8" nylon lock nut)
 Attach one Plastic Pulley (5) to the flanges on the bottom of Top Frame (J) using:
One 14 (3/8" x 1 3/4" hex head bolt)
Two 21 (3/8" washer)
One 31 (3/8" nylon lock nut)
- D. Attach four Plastic Pulley (32) to the two Double Pulley Pivot (E) and (F) using:
Four 10 (1/2" x 2 1/4" hex head bolt)
Eight 20 (1/2" washer)
Four 30 (1/2" nylon lock nut)
- E. Attach Plastic Pulley Wide (6) to the bottom of Chrome Upright (C) using:
One 17 (3/8" x 5" hex head bolt)
Two 21 (3/8" washer)
One 31 (3/8" nylon lock nut)

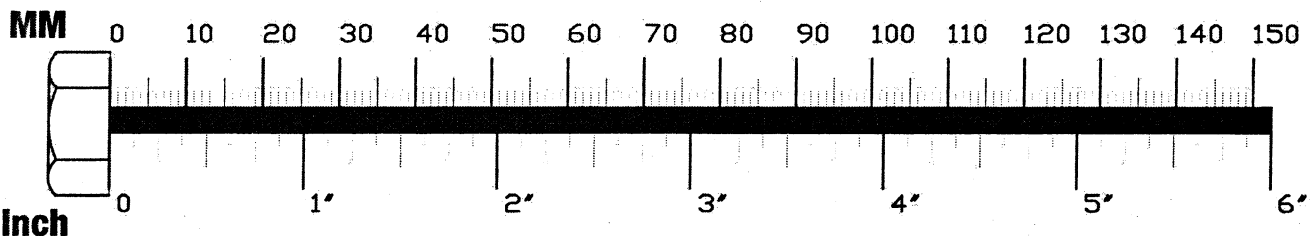

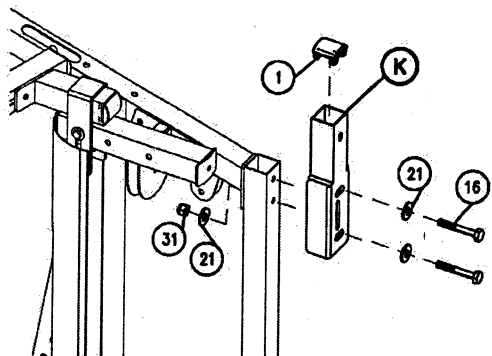

REVERSE SIDE DRAWING

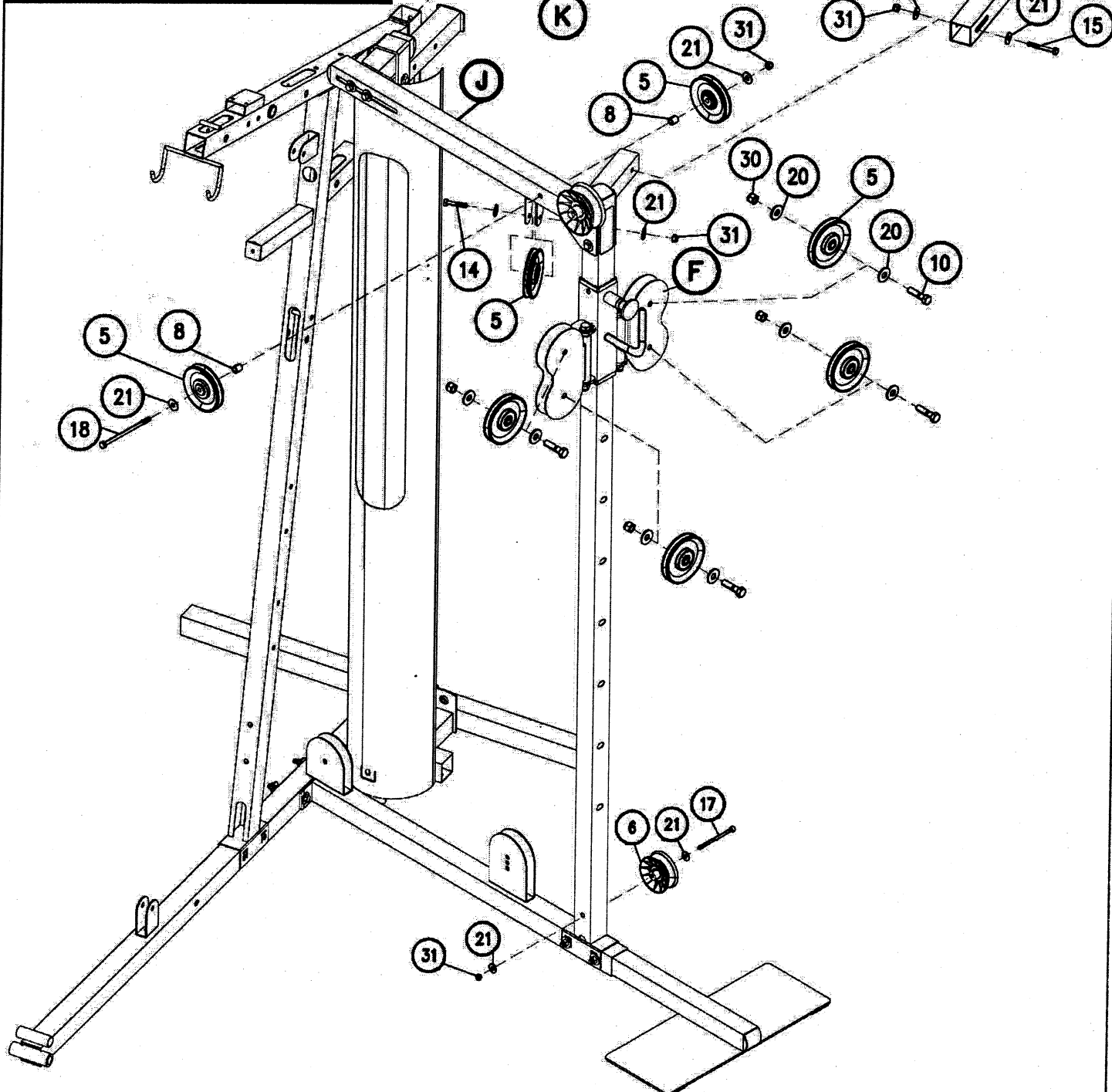

Be careful to assemble all components in the sequence they are presented.

NOTE:

Finger tighten all hardware in this step. Do Not wrench tighten until the end of step 6.

- A. Remove both Cables from plastic bag, and locate the longer Cable. The longer of the two Cables is over 30 feet long, this is Cable number 9. Uncoil Cable (9). Straightening out the Cable first will stop the cable from twisting up, after it has been installed.
- B. Insert Cable (9) into Double Pulley Pivot (E) as shown.
- C. Route Cable between pulleys, and up over the Wide Pulley (6). Route Cable over Plastic Pulley (5) as shown. These two Pulleys are located on the front side of Top Frame (J).
- D. Route Cable through Double Pulley Holder (M), and hold in place by installing Small Pulley (4) using:
***One 15 (3/8" x 2 1/2" hex head bolt)**
Two 21 (3/8" washer)
One 31 (3/8" nylon lock nut)

***NOTE:**

Leave Bolt 15 hand tight, you will be routing the Cable around the second Small Pulley (4), in Step 5.

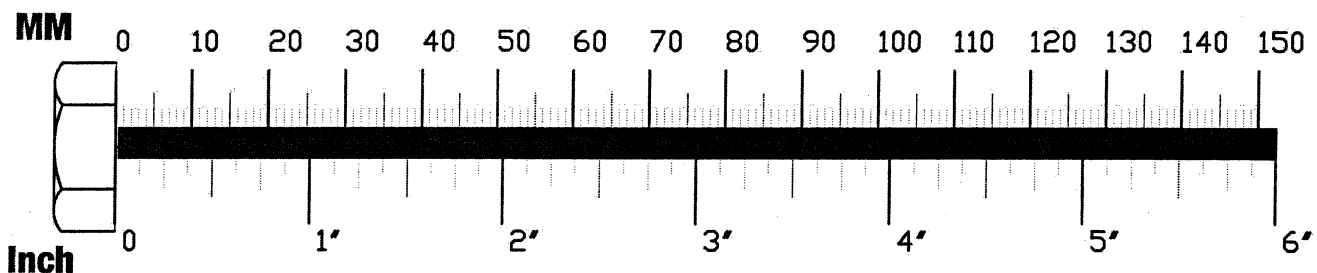

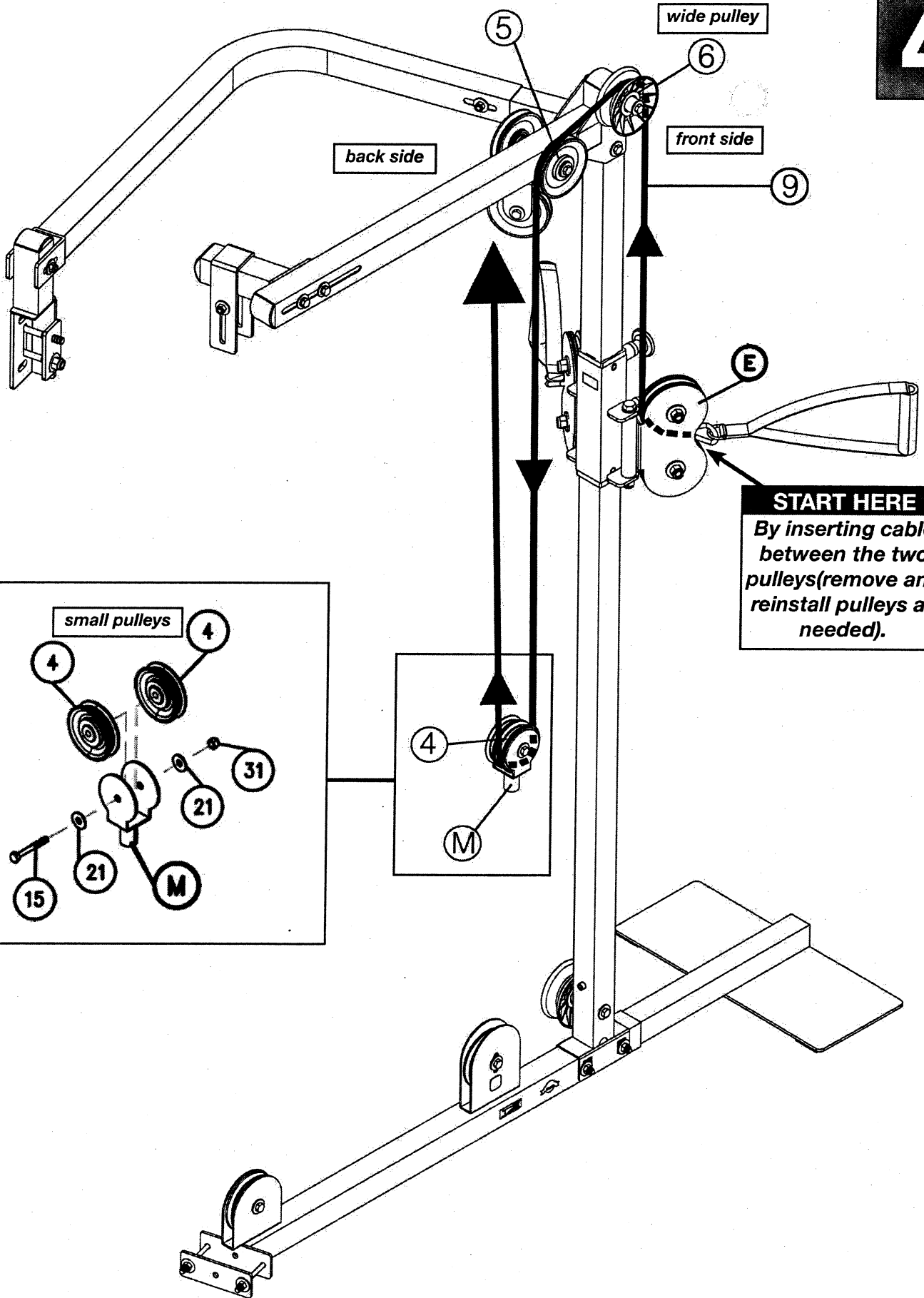

START HERE
By inserting cable between the two pulleys (remove and reinstall pulleys as needed).

Be careful to assemble all components in the sequence they are presented.

NOTE:

Finger tighten all hardware in this step. Do Not wrench tighten until the end of step 6.

NOTE:

The picture on page 15 is from the reverse angle, from the back of the gym.

- A. Route Cable (9) up to the angled Pulley (5), this is the Pulley hanging from Top Frame (J), and route Cable over Pulley. When routing over this pulley, insert the cable over the pulley from back to front. The front being the side the Top Wide Pulley is on.
- B. Route Cable down and through Double Pulley Holder (M), and hold in place by installing a second Small Pulley (4).
- C. Route Cable (9) up to Pulley (5), this is the Pulley on the back side of Top Frame (J), and route over Pulley as shown on page 15. Make sure the cable is parallel to itself, and not crossing. If necessary switch the cable between the two pulleys inside Double Pulley Holder (M).
- D. Route Cable Down and under Wide Pulley (6) at the bottom of Chrome Upright (C). Route Cable up and through Double Pulley Pivot (E) as shown on page 15. Remove and reinstall pulleys as needed.

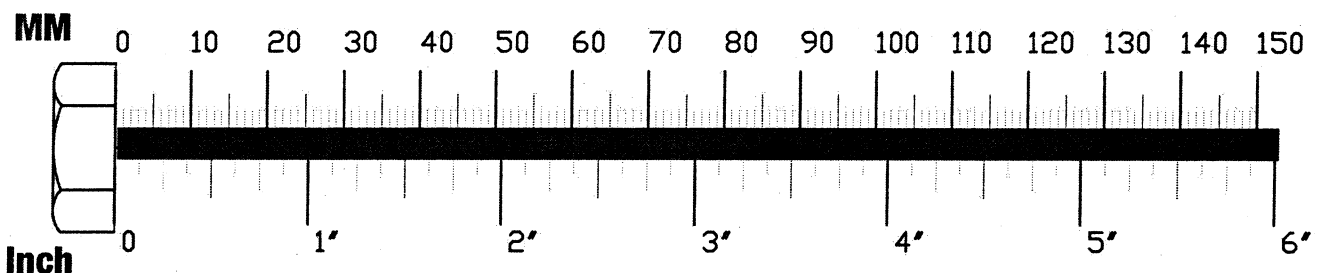

Reverse Side Drawing

STEP

5

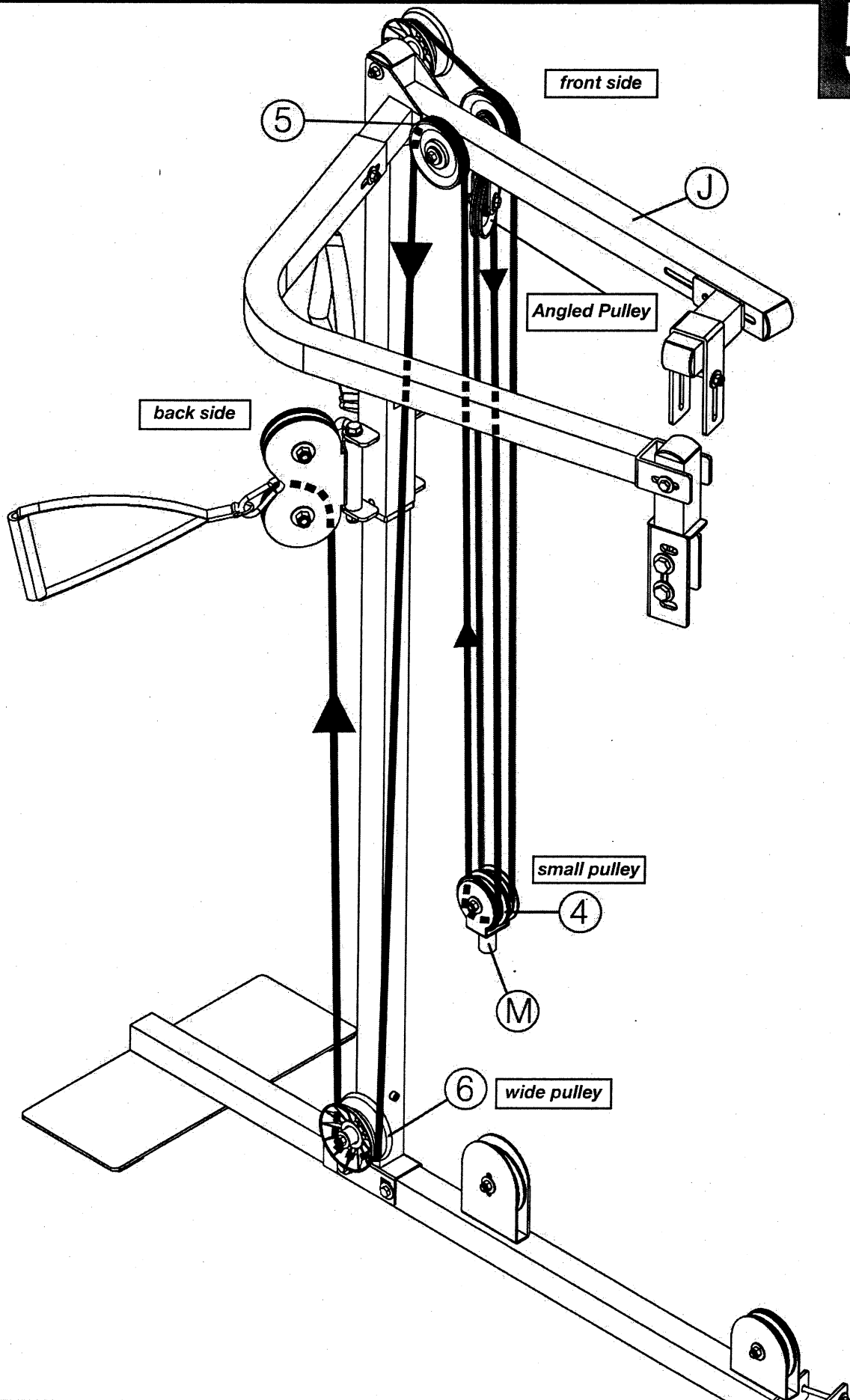

Be careful to assemble all components in the sequence they are presented.

- A. Disconnect your gym's small cable from the Main Support Frame of your gym and the hook at the bottom of the free floating pulley. Discard this cable.
- B. Connect Cable (35) to the hook at the bottom of the free floating pulley of your gym. Route Cable (35) through the two pulley flanges on top of Main Base Frame (A).
- C. Attach two Plastic Pulleys (5) to Main Base Frame (A) on top of Cable using:
Two 14 (3/8" x 1 3/4" hex head bolt)
Four 21 (3/8" washer)
Two 31 (3/8" nylon lock nut)
- D. Connect Cable (35) to the bottom of Double Pulley Holder (M). By wrench tightening the threaded end of Cable (35) into the bottom of Double Pulley Holder (M) using the Spring Lock Washer (38) and Lock Nut (39) that is packaged in a separate bag marked:
"Use to attach Cable 35 to Double Pulley Holder (M)."
- E. Go back and wrench tighten all hardware.

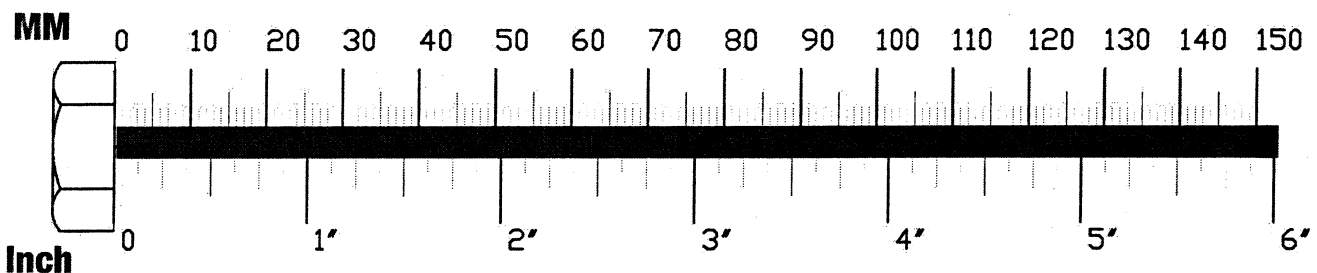

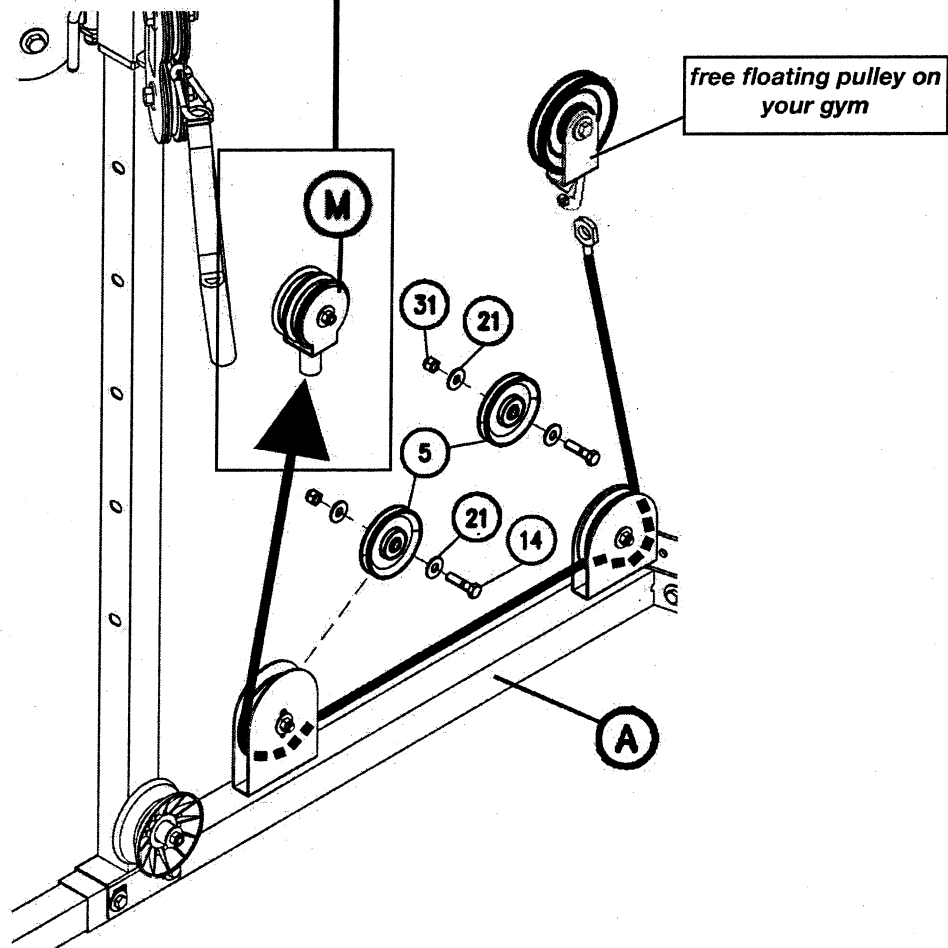
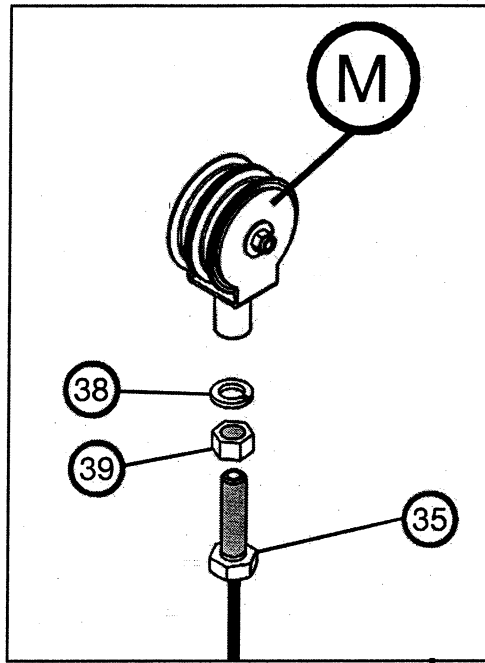

GCCA Main Frame Parts List

| KEY# | QTY | PART# | DESCRIPTION |
|-------------|------------|--------------|--------------------------|
| A | 1 | GCCAMBF-A | MAIN BASE FRAME |
| B | 1 | GCCAFP-B | FOOT PLATE |
| C | 1 | GCCACU-C | CHROME UPRIGHT |
| D | 1 | GCCAAPH-D | ADJUSTABLE PULLEY HOLDER |
| E | 1 | GCCADPP-E | DOUBLE PULLEY PIVOT |
| F | 1 | GCCADPP-F | DOUBLE PULLEY PIVOT |
| G | 1 | GCCATFA-G | TOP FRAME ATTACHMENT |
| H | 1 | GCCATFC-H | TOP FRAME CLAMP |
| J | 1 | GCCATF-J | TOP FRAME |
| K | 1 | GCCATSA-K | TOP SUPPORT ATTACHMENT |
| L | 1 | GCCATFS-L | TOP FRAME SUPPORT |
| M | 1 | GCCADPH-M | DOUBLE PULLEY HOLDER |

Key #, Part #, and Discription are required when ordering parts.

GCCA Hardware List

| KEY# | QTY | PART# | DESCRIPTION |
|------|-----|---------------|--|
| 1 | 4 | CEC22 | CONVEX END CAP 2" X 2" |
| 2 | 2 | NB22 | NYLON BUSHING 2" X 2" |
| 3 | 1 | FPP4 | FLAT POP PIN 4" |
| 4 | 2 | PPS3.5X.75 | PLASTIC PULLEY SMALL 3 1/2"OD X 3/4"W |
| 5 | 5 | PP4.25X.75 | PLASTIC PULLEY 4 1/4"OD X 3/4"W |
| 6 | 2 | PP4.25X1.5 | PLASTIC PULLEY WIDE 4 1/4"OD X 1 1/2"W |
| 7 | 2 | RP2X4 | RUBBER PAD 2" X 4" |
| 8 | 2 | S.37X.75 | SPACER 3/8"ID X 3/4"L |
| 9 | 1 | GCCAC30 | CABLE (length 30' 10") |
| 10 | 4 | HEX.5X2PT | HEX HEAD BOLT 1/2" X 2 1/4" PARTIAL THREAD |
| 11 | 1 | SOC.31X.5FT | SOCKET HEAD BOLT 5/16" X 1/2" FULL THREAD |
| 12 | 2 | HEX.5X6.5PT | HEX HEAD BOLT 1/2" X 6 1/2" PARTIAL THREAD |
| 14 | 3 | HEX.37x1.75PT | HEX HEAD BOLT 3/8" X 1 3/4" PARTIAL THREAD |
| 15 | 4 | HEX.37x2.75PT | HEX HEAD BOLT 3/8" X 2 1/2" PARTIAL THREAD |
| 16 | 7 | HEX.37x3PT | HEX HEAD BOLT 3/8" X 3" PARTIAL THREAD |
| 17 | 1 | HEX.37x5PT | HEX HEAD BOLT 3/8" X 5" PARTIAL THREAD |
| 18 | 1 | HEX.37x5.5PT | HEX HEAD BOLT 3/8" X 5 3/4" PARTIAL THREAD |
| 20 | 8 | WFLT.5 | WASHER 1/2" x 1 3/8" OD |
| 21 | 32 | WFLT.37 | WASHER 3/8" x 1 1/8" OD |
| 22 | 2 | SLW.37 | SPRING LOCK WASHER 3/8" |
| 30 | 6 | NLN.5 | NYLON LOCK NUT 1/2" |
| 31 | 15 | NLN.37 | NYLON LOCK NUT 3/8" |
| 32 | 4 | PP4.25X1 | PLASTIC PULLEY 4 1/2" OD X 1" W |
| 33 | 1 | CEC1.75X1.75 | CONVEX END CAP 1 3/4" X 1 3/4" |
| 34 | 4 | WFLT.5X1 | WASHER 1/2" X 1" OD |
| 35 | 1 | GCCAC6 | CABLE (length 6' 3 1/2") |
| 36 | 2 | HEX.37X4PT | HEX HEAD BOLT 3/8" X 4" PARTIAL THREAD |
| 37 | 1 | FLTPL2X5.5 | FLAT PLATE 2" X 5 1/2" |
| 38 | 1 | SLW.5 | SPRING LOCK WASHER 1/2" |
| 39 | 1 | LN.5 | LOCK NUT 1/2" |

Key #, Part #, and Discription are required when ordering parts.

EXPLODED VIEW DIAGRAM GCCA

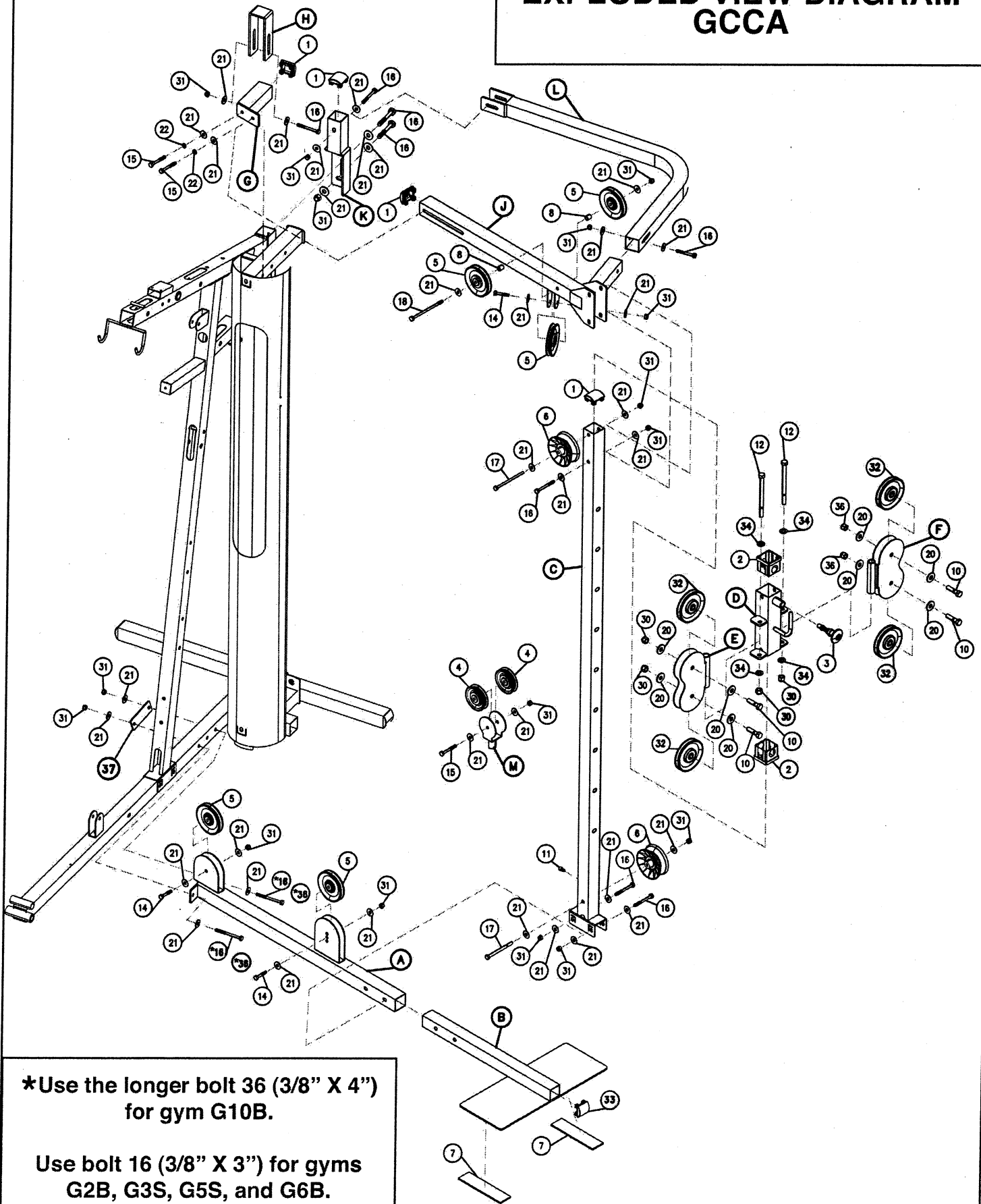

***Use the longer bolt 36 (3/8" X 4")
for gym G10B.**

**Use bolt 16 (3/8" X 3") for gyms
G2B, G3S, G5S, and G6B.**