



**T100D**



**Endurance® T00D Treadmill**

**User Manual**

v. T100D-030513

# Table of Contents

---

I.	REFERENCE DRAWINGS.....	3
II.	BEFORE YOU BEGIN.....	4
III.	IMPORTANT SAFETY INSTRUCTIONS.....	5
IV.	SAFETY GUIDELINES.....	6 - 8
V.	ASSEMBLY INSTRUCTIONS.....	9
VI.	ASSEMBLY STEPS.....	10 - 15
VII.	SETTING UP YOUR TREADMILL.....	16
VIII.	OPERATING YOUR TREADMILL.....	17
IX.	OPERATING THE CONSOLE.....	18 - 20
X.	PROGRAM FEATURES.....	21 - 27
XI.	TARGET HEART RATE .....	28 - 29
XII.	CHEST STRAP OPERATION .....	30
XIII.	HEART RATE CONTROL OPERATION.....	31
XIV.	GENERAL MAINTENANCE.....	32 - 33
XV.	TROUBLESHOOTING GUIDE.....	34
XVI.	SETTING/SERVICE GUIDE.....	35 - 36
XVII.	PARTS LIST.....	47 - 40
XVIII.	EXPLODED VIEW DIAGRAM.....	41

# Reference Drawings

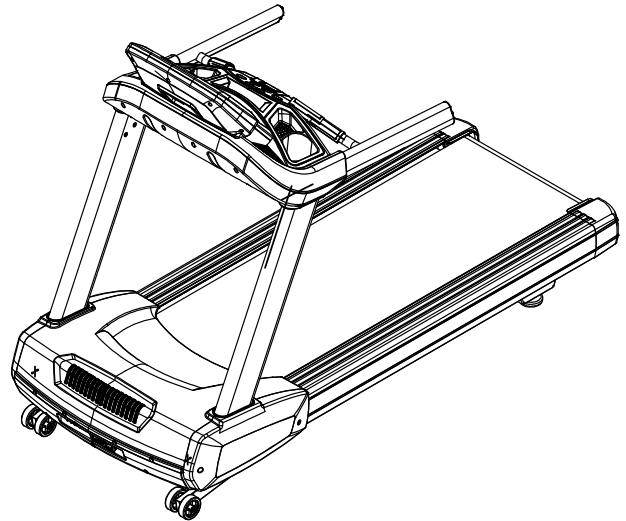
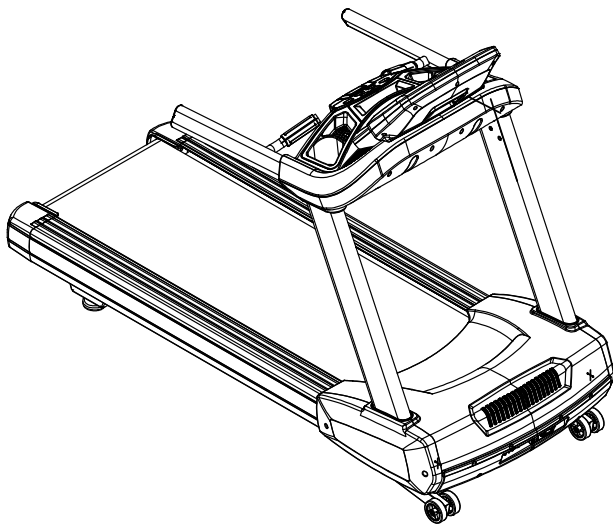
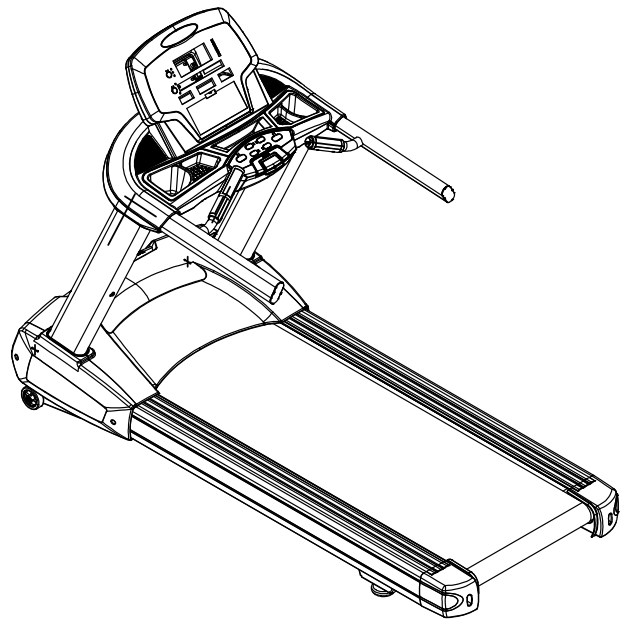
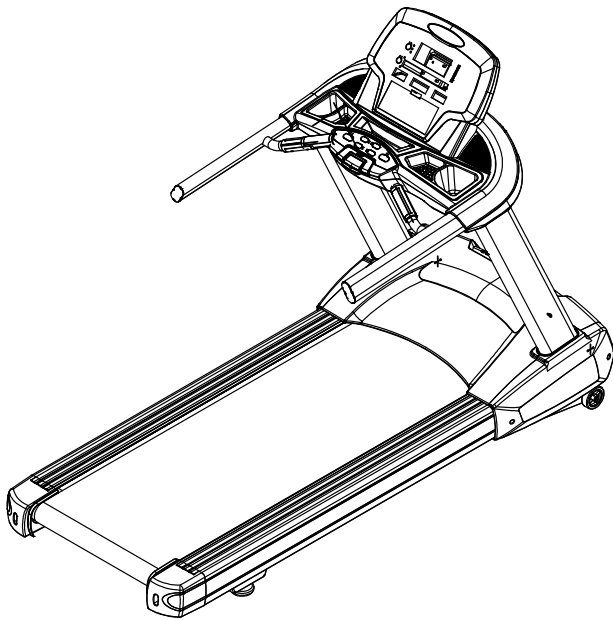

Note: Due to continuing product improvements, specifications and designs are subject to change without notice. Even though we have prepared this manual with extreme care, neither the publisher nor the author can accept responsibility for any errors in, or omission from, the information given.

# Before you Begin

Thank you for purchasing the Endurance T100 Treadmill.  
To maximize your use of the equipment please study this Owner's Manual thoroughly.

---

## UNPACKING THE EQUIPMENT

The T100 is carefully tested and inspected before shipment. We have shipped the unit in several pieces that require assembly. Ask for assistance during the assembly process.

## CAUTION

- Remove the Right and Left Uprights, Console and packing material carefully.
- Hold the treadmill on each side and lift it out from the box carefully.
- Position the treadmill on a flat level surface.
- Read the Owner's Manual carefully before attempting to assemble the treadmill.

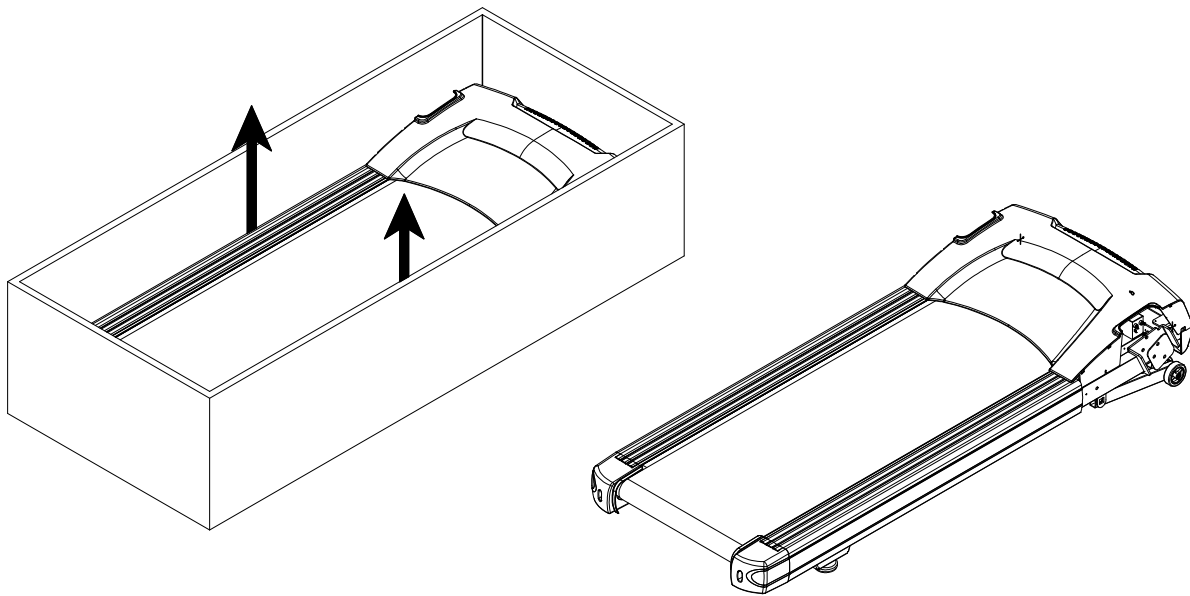

Endurance Equipment continually seeks ways to improve the performance, specifications and product manuals in order to ensure that only superior products are released from our factories. Please take the time to carefully read through this manual thoroughly. Instructions contained in this document are not intended to cover all details or variations possible with Endurance Equipment, or to cover every contingency that may be met in conjunction with installation, operation, maintenance or troubleshooting of the equipment. Even though we have prepared this manual with extreme care, neither the publisher nor the author can accept responsibility for any errors in, or omission from, the information given. Should additional information be required, or should situations arise that are not covered by this manual, the matter should be directed to your local Endurance Equipment representative, or the Service Department at Endurance Equipment in Forest Park, Illinois.

Any Questions?  
Call (800) 556-3113

# Important Safety Instructions

Before beginning any fitness program, you should obtain a complete physical examination from your physician.

*Il est conseillé de subir un examen médical complet avant d'entreprendre tout programme d'exercice. Si vous avez des étourdissements ou des faiblesses, arrêtez les exercices immédiatement.*

---

**When using exercise equipment, you should always take basic precautions, including the following:**

- Read all instructions before using the T100. These instructions are written to ensure your safety and to protect the unit.
- Do not allow children on or near the equipment.
- Use the equipment only for its intended purpose as described in this guide. Do not use accessory attachments that are not recommended by the manufacturer. Such attachments might cause injuries.
- Wear proper exercise clothing and shoes for your workout, no loose clothing.
- Use care when getting on or off the unit.
- Do not overexert yourself or work to exhaustion.
- If you feel any pain or abnormal symptoms, stop your workout immediately and consult your physician.
- Never operate the unit after it has been dropped or damaged. Return the equipment to a service center for examination and repair.
- Never drop or insert objects into any opening in the equipment.
- Always check the unit before each use. Make sure that all fasteners are secure and in good working condition.
- Do not use the equipment outdoors or near water.

## **PERSONAL SAFETY DURING ASSEMBLY**

- It is strongly recommended that a qualified dealer assemble the equipment. *Assistance is required.*
- Before beginning assembly, please take the time to read the instructions thoroughly.
- Read each step in the assembly instructions and follow the steps in sequence. Do not skip ahead. If you skip ahead, you may learn later that you have to disassemble components and that you may have damaged the equipment.
- Assemble and operate the T100 on a solid, level surface. Locate the unit a few feet from the walls or furniture to provide easy access.

The T100 is designed for your enjoyment. By following these precautions and using common sense, you will have many safe and pleasurable hours of healthful exercise with your Endurance T100.

After assembly, you should check all functions to ensure correct operation. If you experience problems, first recheck the assembly instructions to locate any possible errors made during assembly. If you are unable to correct the problem, call the dealer from whom you purchased the machine or call 1-800-556-3113 for the dealer nearest you.

U

# Safety Guidelines

---

Successful cardio training programs have one prominent feature in common...safety. Cardio training has some inherent dangers, as do all physical activities. The chance of injury can be greatly reduced or completely removed by using correct running techniques, proper breathing, maintaining equipment in good working condition, and by wearing the appropriate clothing.

---

- **It is highly recommended that you consult your physician before beginning any exercise program. This is especially important for individuals over the age of 35, or persons with pre-existing health problems.**
- **Always warm up before starting a workout. Try to do a total body warm up before you start. It is especially important to warm up the specific muscle groups you are going to be using. This can be as simple as performing a warm up set of high repetitions and light weight for each exercise.**
- **Always wear appropriate clothing and shoes when exercising. Wearing comfortable athletic shoes with good support and loose fitting, breathable clothing will reduce the risk of injury.**
- **Maintaining equipment in proper operating condition is of utmost importance for a safe cardio training program.**
- **Read and study all warning labels on this machine. It is absolutely necessary that you familiarize yourself and all others with the proper operation of this machine prior to use.**
- **Keep hands, limbs, loose clothing and long hair well out of the way of all moving parts.**
- **Inspect the machine daily for loose or worn parts. If a problem is found do not allow the machine to be used until all parts are tightened or worn or defective parts are repaired or replaced.**
- **To reduce the risk of burns, fire, electric shock, or injury to persons, install the treadmill on a flat level surface with access to a 120VAC, 15Amp, grounded outlet.**
- **Do not use an extension cord unless it is 14awg or larger, with only one outlet on the end. the treadmill should be the only appliance in the electrical circuit. do not attempt to disable the grounded plug by using improper adapters, or in any way modify the cord set. a serious shock or fire hazard may result along with computer malfunctions.**

# Safety Guidelines

Before beginning any exercise program, always consult with your physician. If you experience chest pains, nausea, dizziness or shortness of breath, stop exercising and consult your physician before continuing.

## GROUNDING INSTRUCTIONS

This product must be *grounded*! If the treadmill should malfunction or breakdown, grounding provides a path of least resistance for electrical current to reduce the risk of electrical shock. This product is equipped with a cord having an equipment grounding conductor and a grounding plug. This plug must be inserted in an appropriate outlet that is properly installed and grounded in accordance with local codes and ordinances.

*The outlet selected should be a dedicated electrical circuit. It is particularly important that no sensitive electrical equipment, such as a computer or TV, share the same electrical circuit.*

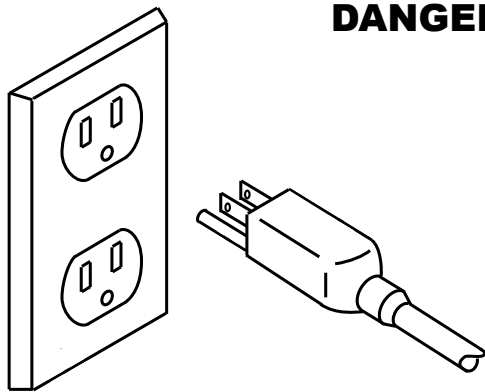

### **DANGER!**

Improper connection of the equipment-grounding conductor can result in a risk of electric shock. Check with a qualified electrician or serviceman if you are in doubt as to whether the product is properly grounded. Do not modify the plug provided with the product – if it will not fit the outlet, have a proper outlet installed by a qualified electrician.

*To reduce the risk of electrical shock, always unplug the treadmill from the electrical outlet immediately after using and before cleaning.*

## ELECTRICAL SAFETY

To reduce the risk of burns, fire, electrical shock, or injury to persons, take the following precautions:

- When plugged in, do not leave the treadmill unattended at any time. Unplug the treadmill from the power source when it is not in use, before adjusting, putting on or taking off parts.
- Use this treadmill only for its intended use as described in this manual.
- Do not use this treadmill if the unit is wet or the plug or cable is damaged or the treadmill is not working properly. Do not use damaged or defective equipment.
- Keep the power cable plugged away from heated surfaces.
- Never place the power cord under carpeting or place any object on top of the power cord.
- Use only the power cord provided with this treadmill.
- To disconnect the plug, turn the switch to the off position, then remove the plug from the outlet.

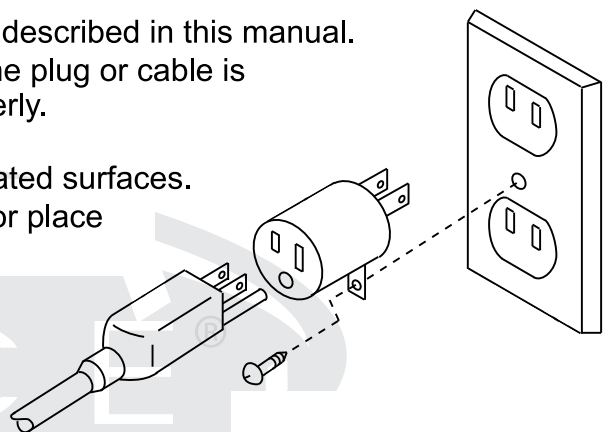

# Safety Guidelines

This exercise equipment is designed and built for optimum safety for home use. However, certain precautions always apply whenever you operate any exercise equipment.

Be sure to read the entire manual before assembly and operation of this machine. Also, please note the following safety precautions.

---

## MECHANICAL SAFETY

- Inspect the equipment prior to exercising to ensure that all nuts and bolts are fully tightened before each use.
- Replace any defective components immediately and/or keep the equipment out of use until repair.
- Do not use attachments not recommended by the manufacturer.
- Never drop or insert an object into any opening.
- Only one person may use the treadmill at a time.
- Never activate the treadmill when someone is standing on the belt.

## APPROPRIATE ATTIRE

- Always wear appropriate clothing.  
Do not wear loose clothing that might catch on any part of this treadmill.
- Always wear non-slippery shoes while working with the treadmill.  
Do not wear shoes with heels or leather soles.  
Check the soles of your shoes and remove any dirt and embedded stones.

## CHILDREN AND PETS

- Most exercise equipment is not recommended for small children.  
Children should not use the equipment unless they are under *strict* adult supervision.  
To ensure safety, keep young children off the treadmill at all times.
- Exercise equipment has many moving parts.  
In the interest of safety, keep others (especially children and pets) at a safe distance while you exercise.

### FCC WARNING - POSSIBLE RADIO/TELEVISION INTERFERENCE

**NOTE:** This equipment has been tested and found to comply with Part 15 of the FCC rules. These limits are designed to provide reasonable protection against harmful interference in a residential installation. Any changes or modifications not expressly approved by the party responsible for the compliance could void the user's authority to operate the equipment. This equipment generates, uses and can radiate radio frequency energy and, if not installed and used in accordance with the instructions, may cause harmful interference to radio communications. However, there is no guarantee that the interference will not occur in a particular installation.

If this equipment does cause harmful radio interference to radio or television reception, which can be determined by turning the equipment off and on, you are encouraged to try to correct the interference by one or more of the following measures:

*Class R (Residential): Private or non-commercial use*

- Reorient or relocate the receiving antenna
- Increase space between the equipment
- Plug the equipment into two electrical outlet located on separate circuits
- Consult an exercise equipment dealer or an experienced radio/TV technician for help

# Assembly Instructions

Assembly of the T100 takes professional installers about 1/2 hour to complete. If this is the first time you have assembled this type of equipment, plan on significantly more time.

## Professional installers are highly recommended!

However, if you acquire the appropriate tools, obtain assistance, and follow the assembly steps sequentially, the process will take time, but is fairly easy.

### ASSEMBLY TIPS

Read all “NOTES” on each page before beginning each step.

While you may be able to assemble the T100 using the illustrations only, important safety notes and other tips are included in the text.

Some pieces may have extra holes that you will not use. Use only those holes indicated in the instructions and illustrations.

*NOTE: To find out the length of a particular bolt, measure its shank (the long, narrow part beneath the head).*

Refer to the following diagram:

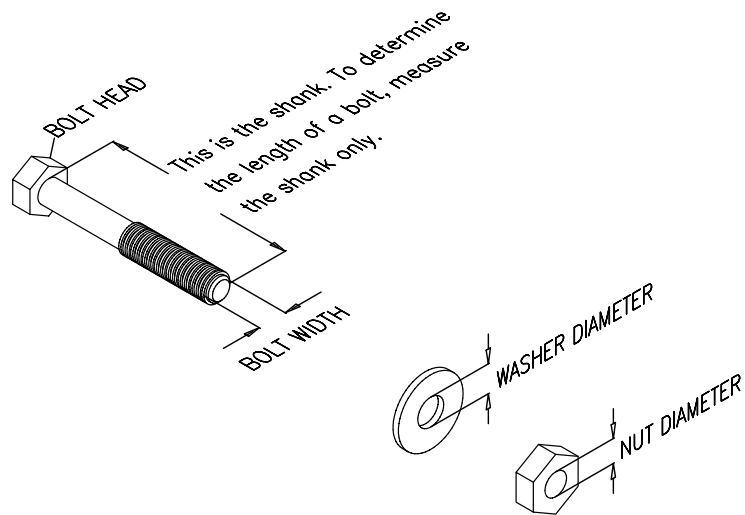

**Do not fully tighten bolts until instructed to do so.**

*NOTE: After assembly, you should check all functions to ensure correct operation. If you experience problems, first recheck the assembly instructions to locate any possible errors made during assembly. If you are unable to correct the problem, call the dealer from whom you purchased the machine or call 1-800-556-3113 for the dealer nearest you.*

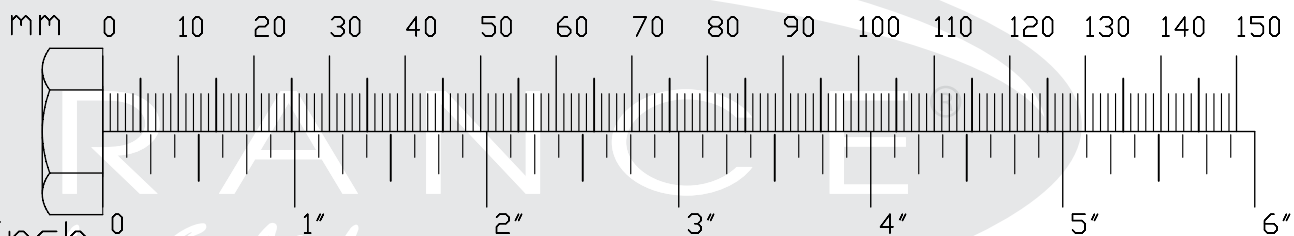

UKRAINIAN  
by Body-Solid

# Step 1

**Be careful to assemble all components in the sequence they are presented.**

- A. Attach Right Upright (#34) to Frame Base using:  
**One Retaining Plate (#98)**  
**Three 3/8"-16 x 3" Button Head Socket Bolts (#144)**  
**Three 3/8" Lock Washers (#117)**  
**Three 3/8" Flat Washers (#116)**

Note: The right upright (34) is with preinstalled lower computer cable A. To install uprights on the frame base, special care must be taken not to pinch the cable between the upright and frame base.

- B. Attach Left Upright (#33) to Frame Base using:  
**One Retaining Plate (#98)**  
**Three 3/8"-16 x 3" Button Head Socket Bolts (#144)**  
**Three 3/8" Lock Washers (#117)**  
**Three 3/8" Flat Washers (#116)**
- C. Attach Motor Base Caps (#26 & #27) to Frame Base using  
**Four M5x12mm Phillips Head Screws (#134)**

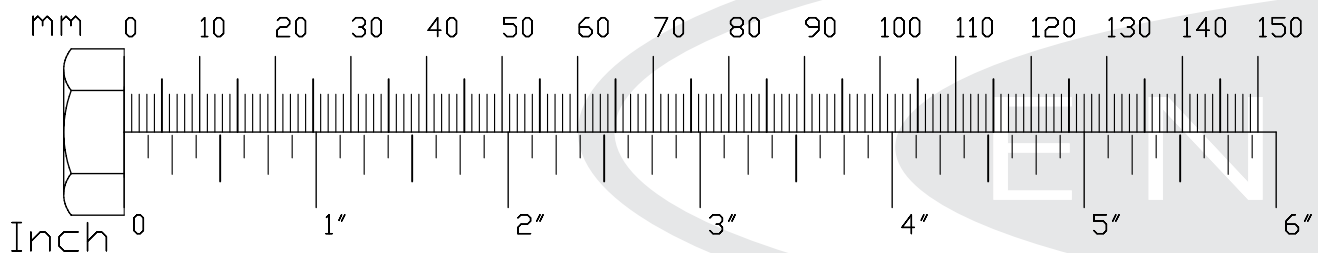

# Step 1

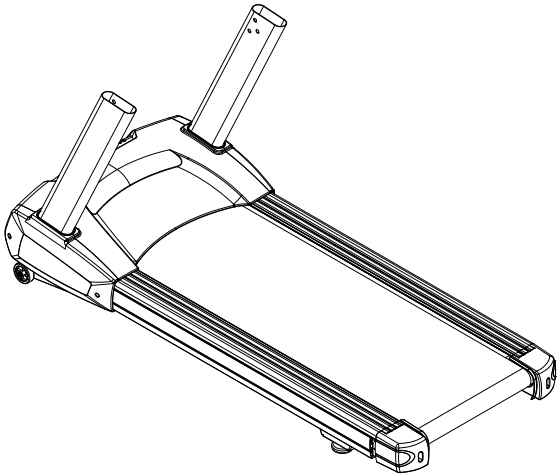

Above shows STEP 1 assembled and completed.

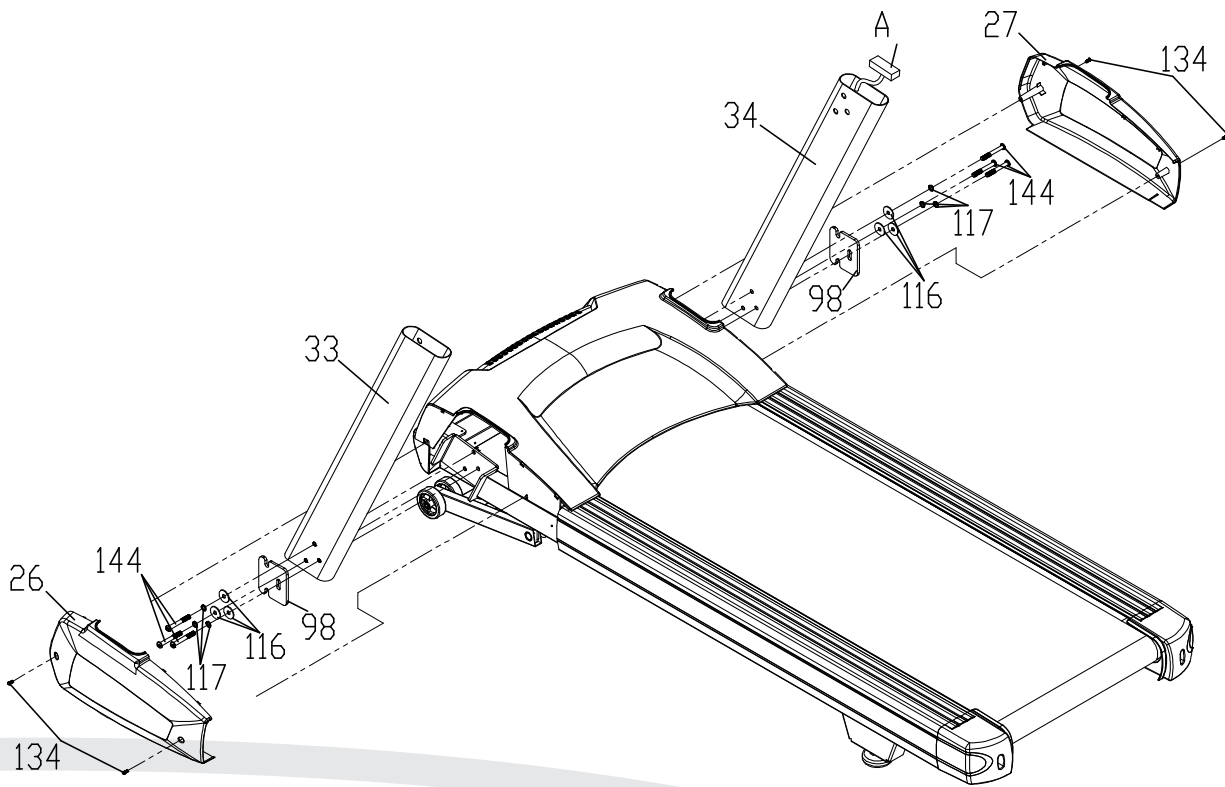

## Step 2

**Be careful to assemble all components in the sequence they are presented.**

- A. Connect Upper Computer Cable B (#41), Hand Pulse Assembly C & D (#37 & #38), Touch Pad/Backlit Cable E(#43) and Ground Wire F (#35) to the board on on back of the console (#28)
- B. Attach Console Assembly (#28) to Console Support (#5) using:  
**Four M5x12mm Phillips Head Screws (#134)**

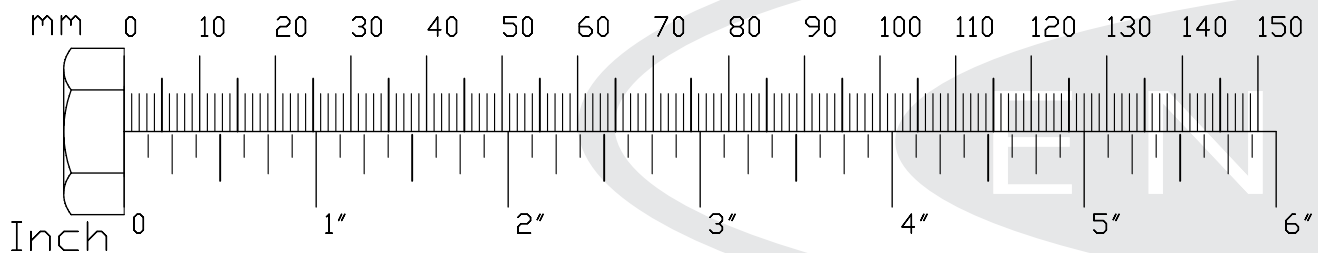

# Step 2

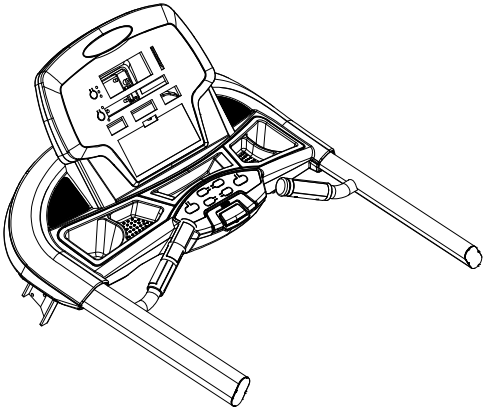

Above shows STEP 2 assembled and completed.

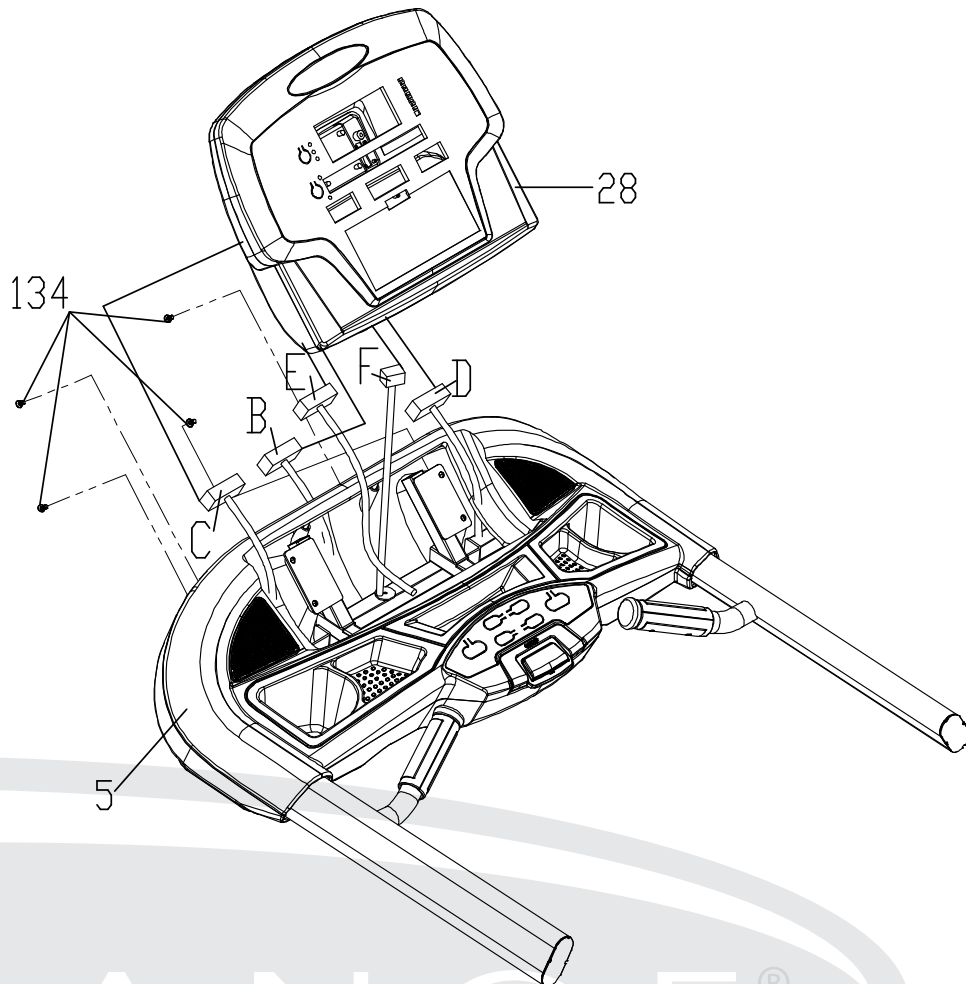

# Step 3

**Be careful to assemble all components in the sequence they are presented.**

- A. Attached the console to Mounting Brackets (#3 & #4) using:  
**Six M8x12mm Socket Head Cap Screws (#146)**
- B. Connect Upper Computer Cable F (#41) to Lower Computer Cable A (#42)
- C. Attach the Mounting Brackets (#3 & #4) to the Uprights using:  
**Six 3/8"-16 x 3/4" Button Head Socket Bolts (#145)**  
**Six 3/8" Lock Washer (#117)**  
**Six 3/8" Flat Washer (#125)**

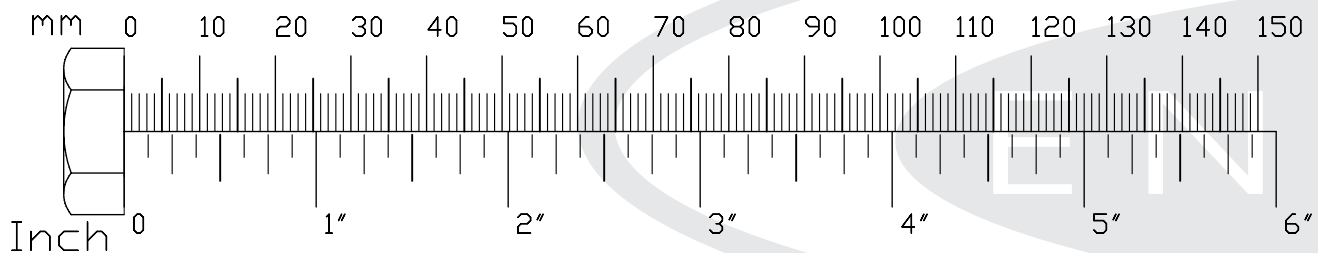

# Step 3

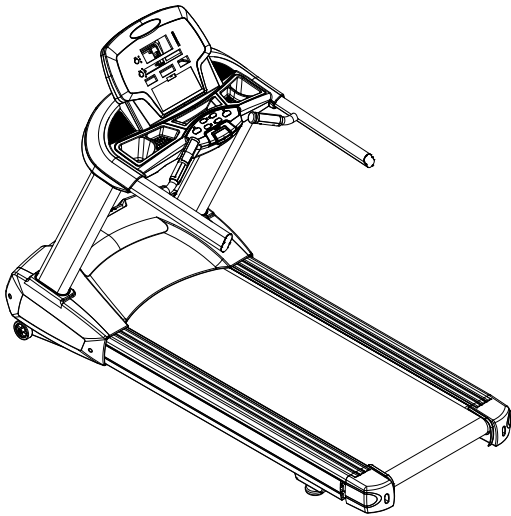

Above shows STEP 3 assembled and completed.

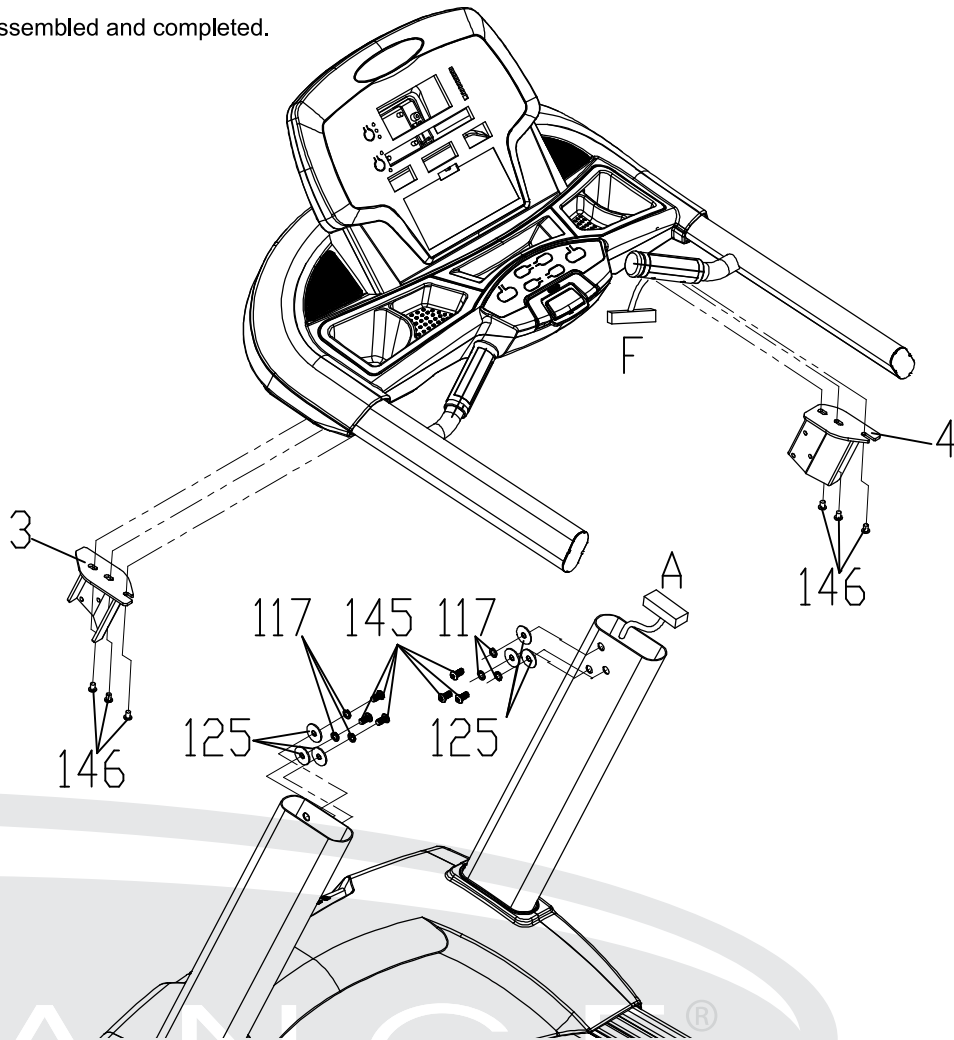

# Setting up your Treadmill

## PLACEMENT IN YOUR HOME

To make exercise a desirable daily activity for you, the treadmill should be placed in a comfortable and attractive setting. This treadmill is designed to use minimal floor space and to fit nicely in your home.

- Do not place or operate the treadmill outdoors.
- Do not place the treadmill near water or in a high moisture content environment.
- Make sure the power cord is not in the path of heavy traffic.
- It is highly recommended to place a dedicated treadmill mat beneath your treadmill. A dedicated mat provides superior stability and firmness for a proper workout.
- Locate the treadmill at least 4 feet from walls or furniture.

Occasionally, after extended use, you will find a fine black dust below your treadmill. This is normal wear and DOES NOT mean there is anything wrong with your treadmill. This dust can be easily removed with a vacuum cleaner. If you wish to prevent this dust from getting on your floor or carpet, place a dedicated treadmill mat beneath your treadmill.

## LEVELING THE BASE

It is important that you place the treadmill on a firm level surface. If the ground is uneven, you may level the treadmill with levelers located under the deck. Make sure the back of the deck is not higher than the front. If adjustments are to be made, check to see if the leverage feet, as shown below, touch the ground firmly. If there is a gap, turn the leverage foot counterclockwise to eliminate the gap.

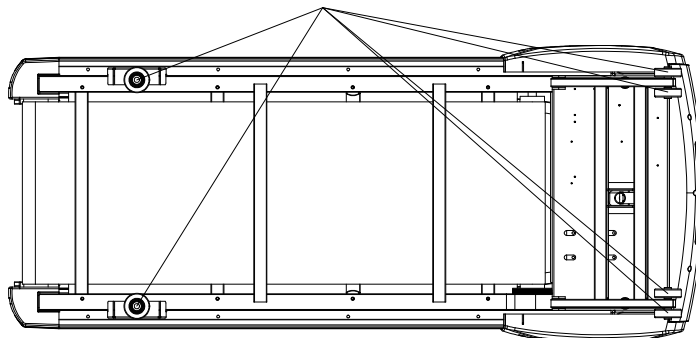

*Make sure the running deck is level to the ground. If the deck is positioned so that you are running downhill, it will cause premature damage to the electronic system*

END

# Operating your Treadmill

## TURN POWER ON

The On/Off switch for the treadmill is located next to the power supply cord receptacle on the front of the treadmill. Insert the power supply cord into the receptacle and flip the switch to the “ON” position.

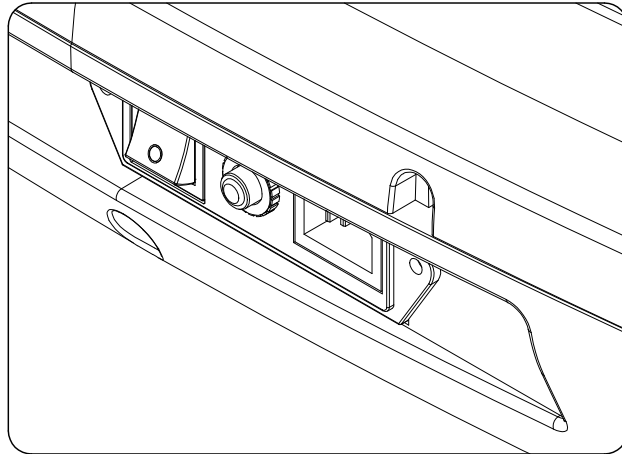

## MOVING THE TREADMILL

This treadmill is easy to move around safely.

To move the treadmill:

1. Turn the power switch off.
2. Unplug the power cord.
3. Lift the rear of the treadmill to a comfortable angle.
4. Simply roll the treadmill on its front two wheels to the desired location.
5. Gently lower the rear of the treadmill to ground level.

## STORE YOUR TREADMILL

*Please follow these safety precautions, especially if you have children at home.*

We suggest to take the following precautions when storing your treadmill.

1. When you finish your workout, turn the power switch to the off position.
2. Remove the plug from the outlet.
3. Remove the safety key.

***It is imperative that the safety key is removed and kept away from children.***

URANCE

by Body-Solid

# Operation of Your Treadmill

## Getting familiar with the control panel

### ■ Console



### Getting Started:

Power the treadmill on by plugging it into an appropriate wall outlet, then turn on the power switch located at the front of the treadmill below the motor hood. Ensure that the safety key is installed, as the treadmill will not power on without it.

When the power is turned on, all the lights on the display will light for a short time. Then the **Time** and **Distance** windows will display Odometer readings for a short time. The **Time** window will show how many hours the treadmill has been in use and the **Distance** window will show how many Kilometers (or Miles if the treadmill is set to English readings; see maintenance for changing settings) the treadmill has gone. A message will be displayed showing the current software version. The treadmill will then enter idle mode, which is the starting point for operation.

# Operating the Console

## Quick-Start Operation:

- Press and release the **START** key to begin belt movement at 0.5 mph/0.8 kph, then adjust to the desired speed using the **FAST** keys.
- To slow tread-belt using the **SLOW** key to the desired speed.
- To stop the tread-belt press and release **STOP** key.

## TREADMILL FEATURES:

### Pause/Stop/Reset:

- When the treadmill is running the pause feature may be utilized by pressing the **STOP** key once. This will slowly decelerate the tread-belt to a stop. The incline stays at that level and Time, Distance and Calorie readings will hold while the unit is in the pause mode. After 5 minutes the display will reset and return to the start up screen.
- To resume your exercise with previous speed and incline settings when in Pause mode, press the **START** key.
- Pressing the **STOP** key twice will end the program and a workout summary will be displayed. If the **STOP** button is pressed a third time, the console will return to the idle mode (start up) screen.
- If the **STOP** button is held down for more than 3 seconds the console will reset.
- When you are setting data, such as age and time, for a program pressing the **STOP** key will allow you to go back one step for each key press.

### Incline:

- Incline may be adjusted anytime after the belt starts moving.
- Press and hold the **UP** or **DOWN** keys to achieve desired level of effort.

### Dot Matrix Center Display:

Ten rows of dots indicate each level of a workout in manual mode. The dots are only to show an approximate level (speed/incline) of effort. They do not necessarily indicate a specific value - only an approximate percent to compare levels of intensity. In Manual Operation the Speed / Incline dot matrix window will build a profile "picture" as values are changed during a workout. There are twenty-four columns, indicating time. The 24 columns are divided into 1/24th of the total time of the program. When the time is counting up from zero (as in quick start) each column represents 1 minute.

URANCE®

by *Body-Solid*

# Operating the Console

Next to the Dot Matrix window are three LED lights labeled: Track, Speed and Incline, along with a **DISPLAY** button. When the Track LED is lit the dot matrix displays the Track profile, when the Speed LED is lit the Dot matrix displays the Speed profile and when the Incline LED is lit the Dot Matrix displays the Incline profile. You may change the Dot Matrix profile view by pressing the DISPLAY button. After scrolling through the three profiles the Dot matrix will automatically scroll through the three displays showing each one for four seconds. The LED associated with each profile will blink while that view is displayed. One more press of the **DISPLAY** button will return you to the Track profile.

## **1/4 Mile Track:**

The 1/4 mile track (0.4km) will be displayed around the dot matrix window. The flashing dot indicates your progress. In the center of the track there is a lap counter for reference.

## **Heart Rate Feature:**

The Pulse (Heart Rate) window will display your current heart rate in beats per minute during the workout. You must use both left and right stainless steel sensors to pick up your pulse. Pulse values are displayed anytime the computer is receiving a Grip Pulse signal. You may use the Grip Pulse feature while in Heart Rate Control. The TREADMILL will also pick up wireless heart rate transmitters that are Polar compatible.

## **Heart Rate Bar Graph:**

Displays a graphical representation of your heart rate as a percentage of your maximum heart rate. When you enter your age during programming, the console will calculate your maximum heart rate then light up the graph to show the percent of maximum heart rate you are currently achieving.

## **Message Window Display:**

Displays messages that help guide you through the programming process. During a program the message window displays your workout data.

## **To Turn Treadmill Off:**

The display will automatically turn off (go to sleep) after 30 minutes of inactivity. This function is called sleep mode. In sleep mode, the treadmill will power down most everything except for a minimum of circuitry for detecting key presses and the safety key so it will start up again if these are activated. There is only a tiny amount of current used in sleep mode (about the same as your TV when it is turned off) and it is perfectly fine to leave the main power switch on in sleep mode.

Of course you may also remove the safety key or turn off the main power switch to power down the treadmill.

END

# Program Features

The New TREADMILL offers twelve preset programs, HILL, FAT BURN, CARDIO, CALORIE, INTERVAL, STRENGTH, 5K RUN, 10K RUN, HR 1, HR 2, CUSTOM, a Gerkin protocol based Fitness Test and one Manual program.

## Preset Features:

### To choose and start preset program:

- Select a program then press the **ENTER** key to begin customizing the program with your personal data, or just press the start key to begin the program with the default settings.
- After selecting a program and pressing **ENTER** to set your personal data, the **Time** window will blink with the default value of 20 minutes. You may use any of the **UP/ DOWN/ FAST/ SLOW** keys to adjust the time. After adjusting the time, press **ENTER**. (Note: Except for program CALORIE, You may press **START** at any time during the programming to begin with only settings you have modified at that point).
- The **INCLINE** window will now be blinking a value indicating your **Age**. Entering the correct Age will affect the Heart rate bar graph accuracy and also needed for the HR programs. Use the **UP/ DOWN/ FAST/ SLOW** keys to adjust, you can also use numeric keypads 0~9 on the console to make adjustments, and then press **ENTER**.
- The **INCLINE** window will now be blinking a value indicating your **Bodyweight**. Entering your correct bodyweight affects the Kcal readout accuracy. Use **UP/ DOWN/ FAST/ SLOW** keys to adjust, you can also use numeric keypads 0~9 on the console to make adjustments, and then press **ENTER**.
- The **SPEED** window will now be blinking, showing the preset top speed of the selected program. Use **UP/ DOWN/ FAST/ SLOW** keys or numeric keys to adjust, you can also use numeric keypads 0~9 on the console to make adjustments, and then press **ENTER**. Each program has various speed changes throughout; this allows you to limit the highest speed the program will attain during your workout.
- Now press the **START** key to begin your workout.

URANCE®

by *Body-Solid*

# Program Features

- There will be a 3 minute warm-up to begin. You can press the START button to bypass this and go straight to the workout. During the warm-up the clock will count down from 3 minutes. ( 5K RUN, 10K RUN, HR 1, HR 2, CUSTOM and the manual program don't have a warm-up mode.)

## Preset programs speed and incline settings

The preset program speed and incline levels are shown in the chart below. The Speed numbers shown in the chart indicate a percentage of the top speed of the program. For instance, the first Speed setting for P1 (Program 1, HILL) shows the number 20. This means that this segment of the program will have a speed that is 20% of the top speed for the program (The user sets the top speed in the procedure above). If the user sets the top speed to 10 mph, then the first segment will be 2 mph. You will notice that segment 12 shows 100 which means, the speed will be set to 100% of 10 mph or simply 10 mph.

Prog	SEG	Warm up	1	2	3	4	5	6	7	8	9	10	11	12	13	14	15	16	17	18	19	20	21	22	23	24	Cool down					
P1	Speed	20	30	40	50	60	60	70	70	70	80	80	70	80	80	100	100	70	80	80	70	70	80	80	70	60	60	50	40	30	20	
	Incline	0	0	0	0	1	2	3	3	4	3	3	4	4	5	3	3	4	3	3	4	4	5	4	3	1	1	0	0	0	0	
P2	Speed	20	30	40	50	60	60	70	80	100	100	100	100	100	100	100	100	100	100	100	100	100	100	80	70	60	50	40	30	20		
	Incline	0	0	0	0	1	2	3	3	3	4	5	3	3	4	4	3	3	2	2	3	4	5	6	4	2	1	0	0	0	0	
P3	Speed	20	30	40	50	60	60	70	70	70	80	70	70	80	80	60	70	80	80	70	70	70	100	70	80	60	60	50	40	30	20	
	Incline	0	0	0	0	1	1	1	2	2	3	2	2	3	3	1	2	3	3	2	2	4	4	2	3	1	1	0	0	0	0	
P4	Speed	20	30	40	50	60	60	70	80	100	60	60	70	80	100	60	70	100	60	70	100	60	70	80	70	60	60	50	40	30	20	
	Incline	0	0	0	0	1	2	3	5	6	2	3	5	6	7	2	3	7	2	3	8	2	3	5	4	3	1	0	0	0	0	
P5	Speed	20	30	40	50	50	60	80	90	100	70	100	70	100	70	100	70	100	70	100	90	80	70	60	50	50	40	30	20			
	Incline	0	0	0	0	0	0	0	0	0	0	0	0	0	0	0	0	0	0	0	0	0	0	0	0	0	0	0	0	0	0	
P6	Speed	20	30	40	50	60	60	70	70	80	80	90	90	90	100	100	100	100	100	100	100	100	100	90	80	60	50	40	30	20		
	Incline	0	0	0	1	1	1	4	4	4	4	4	4	4	4	4	5	5	5	5	5	5	5	5	3	3	3	3	3	1	1	0

P1= HILL P2= FAT BURN P3= CARDIO P4= INTERVAL P5 = CALORIE P6=STRENGTH

## CALORIE Program:

- Press program button "CALORIE" to perform the program. The message window shows "PRESS ENTER TO MODIFY"
- Press "ENTER" button, the message window shows "ADJUST AGE THEN PRESS ENTER" with the INCLINE window is blinking. After the age is set, press "ENTER" to continue.

# Program Features

- Message window is showing "ADJUST BODY WEIGHT THEN PRESS **ENTER**" now with INCLINE window is blinking. After the weight is set, press "**ENTER**" button to continue.
- Message window is showing "ADJUST TARGET CALORIES BURN THEN PRESS **ENTER**" and INCLINE window is blinking. After setting target CALORIE, press "**ENTER**" button to continue.
- Message window now is showing "ADJUST MAX. SPEED THEN PRESS **ENTER**" with SPEED window is blinking. After max. speed is set, press "**ENTER**" button to continue.
- Message window now is showing "ADJUST MAX. INCLINE THEN PRESS **ENTER**" and INCLINE window is blinking. After max. incline is set then press "**ENTER**" button, message window shows "PROGRAM TIME". The console then automatically calculates the time needed and shows it on TIME window.
- Now message window is showing "PRESS START TO BEGIN WORKOUT OR **ENTER** TO MODIFY". Press "**START**" button to start the workout.

## Custom Program:

- Selecting the **Custom** program button, the message window shows "PRESS **ENTER** TO MODIFY OR **START** TO BEGIN WORKOUT". You can either press "**ENTER**" button or press "**START**" button to begin the workout. When you press "**ENTER**" button, dot matrix window will show U1 and flashing. In the mean time, the message window will show "PRESS **1** OR **2** TO SELECT THEN PRESS **ENTER**". You can choose U1 or U2 for setting by pressing "1" or "2" button, then "**ENTER**" button. Note that the dot matrix display portion will light a single row of dots at the bottom (Unless there is a previously saved program).
- After pressing "**ENTER**" button, the message window will show "ADJUST TIME THEN PRESS **ENTER**" with TIME window is blinking. Use the **UP/DOWN/FAST/SLOW** or numeric keypads to adjust and set the program for the desired time. Press the **ENTER** key. This is a must to continue even if the time is not adjusted.
- Now the message window is showing "ADJUST AGE THEN PRESS **ENTER**". The Incline window will now be blinking a value indicating your Age. Entering the correct Age will affect the Heart rate bar graph accuracy. Use **UP/DOWN/FAST/SLOW** keys or numeric keys to adjust and then press **ENTER** key.
- Now the message window is showing "ADJUST SPEED THEN PRESS **ENTER**". The first speed setting column (segment) will now be blinking and SPEED is blinking too. To set the speed value you want, use **FAST / SLOW** keys to adjust the speed to your desired effort level for the first segment then press **ENTER**. The second column will now be blinking. Note that the previous segment value has been carried over to the new segment. Repeat the above process until all segments have been programmed.

URANCE®

by *Body-Solid*

# Program Features

---

- Now the message window is showing "ADJUST INCLINE THEN PRESS ENTER". The first column will be blinking again and INCLINE window is blinking too. The console is now ready for the incline settings. To set the incline value you want, Use **UP/DOWN/FAST/SLOW** keysto adjust the incline to your desired effort level for the first segment then press "**ENTER**".Repeat the same process used to set the speed values for programming the segments for incline.
- When the setting is completed, the message window will show "PRESS START TO BEGIN WORKOUT OR ENTER TO MODIFY" .Press the START button to begin the workout and also save the program to memory.

## **5 Km and 10Km Run:**

This program automatically sets a 5K or 10K (5 or 10 kilometer) distance as your goal. The track display will show one loop that is the equivalent of 5 or 10 kilometers and the Distance window will also show 5K or 10K to start. When the program begins the Distance will count down; once it reaches zero the program ends.

\*Please note that the Speed readout is in MPH if the console is not set to Metric readings.



# Program Features

## Fitness Test:

The fitness test is based on the Gerkin protocol, also known as the fireman's protocol, and is a submax Vo2 (volume of oxygen) test. The test will increase speed and elevation alternately until you reach 85% of your Target heart rate (THR).  $THR = (220 - AGE) \times 0.85$  The time it takes for you to reach THR determines the test score as shown in the chart below.

Stage	Time	Speed	Grade	VO2 Max
1	0 to 1:00	4.5mph	0%	31.15
2.1	1:15	4.5mph	2%	32.55
2.2	1:30	4.5mph	2%	33.6
2.3	1:45	4.5mph	2%	34.65
2.4	2:00	4.5mph	2%	35.35
3.1	2:15	5.0mph	2%	37.45
3.2	2:30	5.0mph	2%	39.55
3.3	2:45	5.0mph	2%	41.3
3.4	3:00	5.0mph	2%	43.4
4.1	3:15	5.0mph	4%	44.1
4.2	3:30	5.0mph	4%	45.15
4.3	3:45	5.0mph	4%	46.2
4.4	4:00	5.0mph	4%	46.5
5.1	4:15	5.5mph	4%	48.6
5.2	4:30	5.5mph	4%	50
5.3	4:45	5.5mph	4%	51.4
5.4	5:00	5.5mph	4%	52.8
6.1	5:15	5.5mph	6%	53.9
6.2	5:30	5.5mph	6%	54.9
6.3	5:45	5.5mph	6%	56
6.4	6:00	5.5mph	6%	57
7.1	6:15	6.0mph	6%	57.7
7.2	6:30	6.0mph	6%	58.8
7.3	6:45	6.0mph	6%	60.2
7.4	7:00	6.0mph	6%	61.2
8.1	7:15	6.0mph	8%	62.3
8.2	7:30	6.0mph	8%	63.3
8.3	7:45	6.0mph	8%	64
8.4	8:00	6.0mph	8%	65
9.1	8:15	6.5mph	8%	66.5
9.2	8:30	6.5mph	8%	68.2
9.3	8:45	6.5mph	8%	69
9.4	9:00	6.5mph	8%	70.7
10.1	9:15	6.5mph	10%	72.1
10.2	9:30	6.5mph	10%	73.1
10.3	9:45	6.5mph	10%	73.8
10.4	10:00	6.5mph	10%	74.9
11.1	10:15	7.0mph	10%	76.3
11.2	10:30	7.0mph	10%	77.7
11.3	10:45	7.0mph	10%	79.1
11.4	11:00	7.0mph	10%	80

URANCE®

by Body-Solid

# Program Features

---

## **Before the test:**

- Make sure you are in good health; check with your physician before performing any exercise if you are over the age of 35 or persons with pre-existing health conditions.
- Make sure you have warmed up and stretched before taking the test.
- Do not take in caffeine before the test.
- If using the hand pulse sensors hold the hand grips gently, do not tense up.

## **Fitness test programming:**

1. Press the Fitness-test button and press ENTER.
2. The message window will ask you to enter your Age. You may adjust the age setting by using UP/ DOWN/ FAST/ SLOW keys or numeric keys, with the adjustment shown in the Incline window, then press the ENTER key to accept the new number and proceed on to the next screen.
3. You are now asked to enter your Weight. You may adjust the weight setting by using UP/ DOWN/ FAST/ SLOW keys or numeric keys, with the adjustment shown in the INCLINE window, then press ENTER to continue.
4. Now press START to begin the test.

## **During the test:**

- The console must be receiving a steady heart rate for the test to begin. You may use the hand pulse sensors or wear a heart rate chest strap transmitter.
- The test will start with a 3 minute warm-up at 5kph (3mph) before the actual test begins.
- The data shown during the test is:
  - a. Time indicates total elapsed time
  - b. Incline in percent grade
  - c. Distance in Miles or Kilometers depending on preset parameter.
  - d. Speed in MPH or KPH depending on preset parameter.
  - e. Target Heart Rate and Actual Heart Rate are shown in the message window.

## **After the test:**

- Cool down for about one to three minutes.
- Take note of your score because the console will automatically return to the start-up mode after a few minutes.

# Program Features

What your score means:

**VO2max for male and fitted female**

	18-25	26-35	36-45	46-55	56-65	65+
	years old	years old	years old	years old	years old	years old
excellent	>60	>56	>51	>45	>41	>37
good	52-60	49-56	43-51	39-45	36-41	33-37
above average	47-51	43-48	39-42	35-38	32-35	29-32
average	42-46	40-42	35-38	32-35	30-31	26-28
below average	37-41	35-39	31-34	29-31	26-29	22-25
poor	30-36	30-34	26-30	25-28	22-25	20-21
very poor	<30	<30	<26	<25	<22	<20

**VO2max for female and non-fitted male**

	18-25	26-35	36-45	46-55	56-65	65+
	years old	years old	years old	years old	years old	years old
excellent	56	52	45	40	37	32
good	47-56	45-52	38-45	34-40	32-37	28-32
above average	42-46	39-44	34-37	31-33	28-31	25-27
average	38-41	35-38	31-33	28-30	25-27	22-24
below average	33-37	31-34	27-30	25-27	22-24	19-22
poor	28-32	26-30	22-26	20-24	18-21	17-18
very poor	<28	<26	<22	<20	<18	<17

URANCE®

by *Body-Solid*

# Target Heart Rate

---

To obtain the greatest cardiovascular benefits from your exercise workout, it is important to work within your target heart rate zone. The American Heart Association (AHA) defines this target as 60% -75% percent of the Maximum Heart Rate.

The Maximum Heart Rate may be roughly calculated by subtracting the user's age from 220.

The Maximum Heart Rate and aerobic capacity naturally decreases as the user ages. This may vary from one person to another, but use this number to find your approximate effective target zone. For example, the Maximum Heart Rate for an average 40 year-old is 180 bpm. The target heart rate zone is 60%-75% of 180 or 108-135 bpm. See the FITNESS SAFETY section.

Before beginning a workout, check the normal resting heart rate. The user can place their fingers lightly against the neck or wrist over the main artery. After finding the pulse, count the number of beats in 10 seconds. Multiply the number of beats by six to determine your pulse rate per minute. It is recommend to take a heart rate measurement at rest, after warming up, during the workout and two minutes into cooling down after the workout, to accurately track progress as it relates to better fitness.

During your first several months of exercising, the AHA recommends aiming for the lower part of the target heart rate zone - 60%, then gradually progressing up to 75%. According to the AHA, exercising above 75% of the Maximum Heart Rate may be too strenuous unless the user is in top physical condition. Exercising below 60% of the maximum will result in minimal cardiovascular conditioning.

## **CHECK YOUR PULSE RECOVERY RATE**

If your pulse is over 100 bpm five minutes after stopping exercising, or if it's higher than normal the morning after exercising, the user's exertion may have been too strenuous for their current fitness level. Rest and reduce the intensity next time.

## **CAUTION!**

The target value used in HR-1 and HR-2 programs is a suggestion only for normal, healthy individuals. Do not exceed your limits! You may not be able to obtain your chosen target. If in question, enter a higher age value that will set a lower target goal.

END

# Target Heart Rate

## FITNESS SAFETY

The Heart Rate chart indicates average rate zones for different ages. A variety of different factors (including medication, emotional state, temperature and other conditions) can affect the target heart rate zone that is best for you. Your physician or health care professional can help you determine the exercise intensity that is appropriate for your age and condition.

(MHR) = *Maximum Heart Rate*  
 (THR) = *Target Heart Rate*

$220 - \text{Age} = \text{Maximum Heart Rate (MHZ)}$   
 $\text{MHZ} \times .60 = 60\% \text{ of your Maximum Heart Rate.}$   
 $\text{MHZ} \times .75 = 75\% \text{ of your Maximum Heart Rate.}$

For example, if you are 30 years old, your calculations will be as follows:  
 $220 - 30 = 190$   
 $190 \times .60 = 114$  (Low End or 60% of MHZ)  
 $190 \times .75 = 142$  (High End or 75% of MHZ)  
 30 Year-Old (THR) Target Heart Rate would be 114-142

*Maximum Heart Rate (MHR) Calculation*

HEART RATE TRAINING ZONE						
MAX	BEATS PER MINUTE					
85%	170	161	153	144	136	128
70%	140	133	126	119	112	105
60%	120	114	108	102	96	90
AGE	20	30	40	50	60	70

*Heart Rate Training Zone Chart* ®

URANCE

by *Body-Solid*

# Chest Strap Operation (Optional)

Your Endurance® T100 Treadmill has the capability to determine Heart Rate with the use of a Heart Rate Chest Strap. It is available as an optional accessory for use with your unit depending on the Endurance® model purchased. In all Heart Rate Control programs, the console only accepts the heart rate signal from the chest strap transmitter while the pulse grip heart rate function is disabled. The requirement to wear the chest strap is due to the superior accuracy of a chest strap transmitter compared to the pulse grip sensors.

It is suggested for the Chest Strap Transmitter that you position the transmitter as close to your heart as possible, against the skin, 1-2 inches below the pectoral muscles. For best results, moisten the back of the transmitter for better contact.

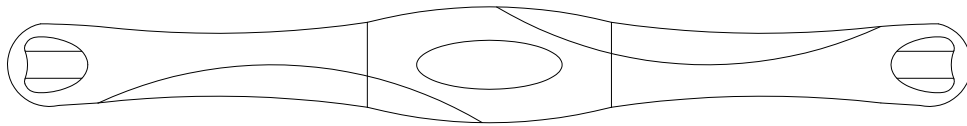

## SAFETY PRECAUTIONS AND TIPS FOR CHEST STRAP

1. It is the owner's responsibility to ensure that all users of this unit have read the Owner's Manual and are familiar with warnings and safety precautions.
2. Do not place chest strap near devices that generate large magnetic fields. TV sets, electric motors, radios, and high voltage power lines can affect the transmitter's performance. These items can interfere with the heart rate signal and possibly affect the heart rate readings on the console.
3. Handle the Chest Strap with care. Dropping the transmitter might cause damage that could void the warranty.
4. Do not use the chest strap if you have a cardiac pacemaker or if you are taking medications for a heart condition. Medication or electrical pulses from the pacemaker can interfere with accurate heart rate readings.
5. Do not bend the strips inside the chest strap. This can cause the chest strap to lose conductivity.
6. The chest strap has batteries that need to be replaced periodically. A faulty battery can cause inaccurate reading.

END

# Heart Rate Control Operation

## How the Heart Rate Control Program Works:

Heart Rate Control (HRC) uses your treadmill's incline system to adjust your heart rate. Increases and decreases in elevation affect heart rate much more efficiently than changes in speed alone. The HRC program automatically changes elevation gradually to achieve the programmed target heart rate.

## Selecting a Heart Rate Control Program:

You have the option, during the setup mode, to choose either the Weight Control (HR-1) program or the Cardiovascular (HR-2) program. The Weight Control program will maintain your heart rate at 70% of your Maximum Heart Rate. The Cardiovascular program will maintain your heart rate at 90% of your Maximum Heart Rate. Your Maximum Heart Rate is based upon a formula that subtracts your age from a constant of 220. Your HR setting is automatically calculated during the setup mode when you enter your age.

## Heart Rate Control Program

**You must receive a strong / steady value in heart rate window or the program will not start.**

- Press Program HR button to enter heart rate control program.
- Now the window will show "PRESS ENTER TO MODIFY OR START TO BEGIN WORKOUT". You can either press "**ENTER**" button for setting or press "**START**" button to execute the program.
- .When "**ENTER**" button is pressed, the message window shows "PRESS 1 OR 2 TO SELECT THEN PRESS ENTER". At the same time, the dot matrix window is showing "1" and you can press numeric keypad 1 or 2 and then "**ENTER**" button..
- Now message window is showing "ADJUST TIME THEN PRESS ENTER" with TIME window is blinking. Use **UP/DOWN/FAST/SLOW** keys or numeric keys to adjust. After setting time, press "**ENTER**" button again.
- Now message window is showing "ADJUST AGE THEN PRESS ENTER" with INCLINE window is blinking. Use **UP/DOWN/FAST/SLOW** keys or numeric keys to adjust. Adjusting age will change THR value. (as the THR formula described above).After age is set, press "**ENTER**" button again.
- Now message window is showing "ADJUST BODY WEIGHT THEN PRESS ENTER" with INCLINE window is blinking. Use UP/DOWN/FAST/SLOW keys or numeric keys to adjust. After the weight is set, press "**ENTER**" button again..
- Now message window is showing "ADJUST HEART RATE THEN PRESS ENTER" with SPEED window is blinking. Use **UP/DOWN/FAST/SLOW** keys or numeric keys to adjust. After the target heart rate value is set, Press "**ENTER**" button again.
- The message window is then showing "PRESS START TO BEGIN WORKOUT OR ENTER TO MODIFY". .Press "**START**" button to begin the workout.

**Note: When the message window is showing "CHECK PULSE", there is no pulse signal received and the program can not be performed. Please check and make sure that Heart Rate strap functions normally.**

URANCE®

by *Body-Solid*

# General Maintenance

**Belt and Bed** - Your treadmill uses a very high-efficient low-friction bed. Performance is maximized when the bed is kept as clean as possible. Use a soft, damp cloth or paper towel to wipe the edge of the belt and the area between the belt edge and frame. Also reach as far as practical directly under the belt edge. This should be done once a month to extend belt and bed life. Use water only - no cleaners or abrasives. A mild soap and water solution along with a nylon scrub brush will clean the top of the textured belt. Allow the belt to dry before using.

**Belt Dust** - This occurs during normal break-in or until the belt stabilizes. Wiping excess off with a damp cloth will minimize buildup.

**General Cleaning** - Dirt, dust, and pet hair can block air inlets and accumulate on the running belt. On a monthly basis: vacuum underneath your treadmill to prevent buildup. Once a year, you should remove the black motor hood and vacuum out dirt that may accumulate. **UNPLUG POWER CORD BEFORE THIS TASK.**

## **BELT ADJUSTMENTS:**

Tread-belt Tension Adjustment - Adjustment must be made from the rear roller. The adjustment bolts are located at the end of the step rails in the end caps, as noted in diagram below.

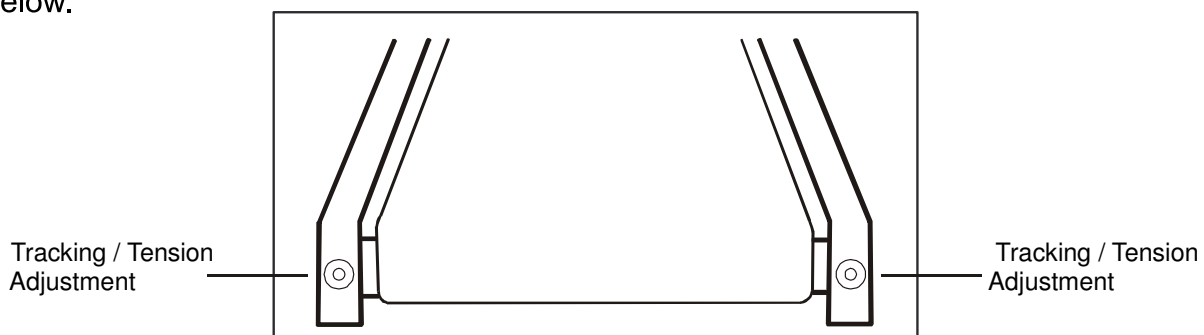

**Note:** Adjustment is through small hole in the end cap.

Tighten the rear roller bolts only enough to prevent slippage at the front roller. Turn both tread-belt tension adjustment bolts in increments of 1/4 turn each and inspect for proper tension by walking on the belt at a low speed, making sure the belt does not slip. Keep tensioning the bolts until the belt stops slipping.

- **If you feel the belt is tight enough, but it still slips, the problem may be a loose Motor drive belt under the front cover.**

**DO NOT OVERTIGHTEN** – Over tightening will cause belt damage and premature bearing failure.

END

# General Maintenance

## TREADBELT TRACKING ADJUSTMENT:

The performance of your treadmill is dependent on the frame running on a reasonably level surface. If the frame is not level, the front and back roller cannot run parallel, and constant belt adjustment may be necessary.

The treadmill is designed to keep the tread-belt reasonably centered while in use. It is normal for some belts to drift near one side while the belt is running with no one on it. After a few minutes of use, the tread-belt should have a tendency to center itself. If, during use, the belt continues to move toward one side, adjustments are necessary.

## TO SET TREADBELT TRACKING:

A 10 mm Allen wrench is provided to adjust the rear roller. Make tracking adjustments from the left side only. Set belt speed at approximately 3 to 5 kph.

Remember, a small adjustment can make a dramatic difference!

Turn the bolt clockwise to move the belt to the right. Turn the bolt only a 1/4 turn and wait a few minutes for the belt to adjust itself. Continue to make 1/4 rotation turns until the belt stabilizes in the center of the running deck.

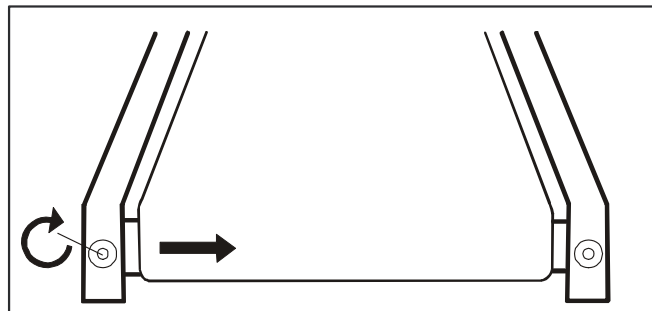

The belt may require periodic tracking adjustment depending on use and walking/running characteristics. Some users will affect tracking differently. Expect to make adjustments as required to center the tread-belt. Adjustments will become less of a maintenance concern as the belt is used. Proper belt tracking is an owner responsibility common with all treadmills.

## ATTENTION:

**DAMAGE TO THE RUNNING BELT RESULTING FROM IMPROPER TRACKING / TENSION ADJUSTMENTS IS NOT COVERED UNDER THE WARRANTY.**

URANCE®

by *Body-Solid*

# Troubleshooting Guide

PROBLEM	SOLUTION/CAUSE
Display does not light	<ol style="list-style-type: none"> <li>1) Tether cord not in position.</li> <li>2) Circuit breaker on front grill tripped. Push circuit breaker in until it locks.</li> <li>3) Plug is disconnected. Make sure plug is firmly pushed into <b>120 VAC</b> wall outlet.</li> <li>4) Breaker panel circuit breaker may be tripped.</li> <li>5) Treadmill defect. Contact your dealer.</li> </ol>
Tread-belt does not stay centered	The user may be walking while favoring or putting more weight on either the left or right foot. If this walking pattern is natural, track the belt slightly off-center to the side opposite from the belt movement.
Treadmill belt hesitates when walked/run on	See General Maintenance section on Tread-belt Tension. Motor drive belt may be loose.
Motor is not responsive after pressing start	<ol style="list-style-type: none"> <li>1) If the belt moves, but stops after a short time and the display shows "Low Speed", run calibration (See procedure on next page).</li> <li>2) If you press start and the belt <b>never</b> moves, then the display shows Low Speed, contact service.</li> </ol>
Treadmill will only achieve approximately <b>7 mph</b> but shows higher speed on display	This indicates motor should be receiving power to operate. Low AC voltage to treadmill. Do not use an extension cord. If an extension cord is required it should be as short as possible and heavy duty 16 gauge minimum. Low household voltage. Contact an electrician or your dealer. A minimum of <b>100 volt</b> AC current.
Treadmill trips on board <b>15 amp</b> circuit	High belt/deck friction. See General Maintenance section.
Computer shuts off when console is touched (on a cold day) while walking/running	Treadmill may not be grounded. Static electricity is "crashing" the computer. Refer to Grounding Instructions on page 3.
House circuit breaker trips, but not the treadmill circuit breaker.	Need to replace the house breaker with a "High inrush current" type breaker (see page 3 for details)



# Setting/Service Guide

## Calibration procedure:

- 1) Remove the safety key
- 2) Press and hold down the **INCLINE** and **SPEED** buttons with one hand and replace the safety key with the other. Continue to hold both keys until the window displays "**FACTORY SETTING**", then press the **ENTER** key.
- 3) You will now be able to set the display to show English or Metric settings. To do this, press **UP/DOWN** or **FAST/SLOW** keys to show which you want, then press **ENTER**.
- 4) Make sure the wheel size diameter is 2.98 then press **ENTER**.
- 5) Adjust the maximum speed (if needed) to 12.0mph or 20.0kph and then press **ENTER**.
- 6) Adjust the minimum speed (if needed) to 0.5mph or 0.8kph and then press **ENTER**.
- 7) Message Windows will show "**INCLINE STEPS**". Adjust the maximum elevation (if needed) to 15 and then press **ENTER**.
- 8) Message Windows will show "**CALIBRATION ON**". Press **START** to begin calibration. The process is automatic; the speed will start up without warning, so do not stand on the belt. After finishing calibration, it automatically returns to **IDLE MODE**.

## Adjusting the speed sensor:

If the calibration does not pass you may need to check the speed sensor alignment.

- 1) Release motor cover screws (screws are not necessarily taken apart) and remove the motor cover hood.
- 2) The speed sensor is located on the left side of the frame, right next to the front roller pulley (the pulley will have a belt around it that also goes to the motor). The speed sensor is small and black square with a wire connected to it.
- 3) Make sure the sensor is as close as possible to the pulley without touching it. You will see a magnet on the face of the pulley; make sure the sensor is aligned with the magnet. There is a screw that holds the sensor in place that needs to be loosened to adjust the sensor. Re-tighten the screw when finished.

## Resetting cumulated distance and time (DIAGNOSTICS PROCESS):

- 1) Remove the safety key and press numeric key **0** and **ENTER** then return the safety key to enter displaying the version of cumulated distance and time. Total time is shown on window **TIME** while total mileage and software version on window **MW**.
- 2) To clear the value, press numeric keys **7** → **8** → **9** → **7** then press **ENTER** key to reset total mileage and time to zero.
- 3) Press **STOP** key to exit and return idle mode.

URANCE®

by *Body-Solid*

# Setting/Service Guide

## Maintenance menu:

- 1) Remove the safety key and press **SPEED** and **ENTER** keys at the same time then return the safety key until “ENGINEERING MODE” is displayed, press **ENTER** again.
- 2) You can now scroll through the menu using the **UP /DOWN** or **FAST/SLOW** keys. Use the **ENTER** key to run. Use the **STOP** key to return to previous menu selection. The menu selections are:
  - 1) **Key Test** – Press each key to verify it is functioning correctly. Press **ENTER** key to run.
  - 2) **Display test** - Lights all LED lights. Press **ENTER** key to run.
  - 3) **Functions** (Press **ENTER** key into this function)
    - i. **Sleep** - Turns sleep mode on or off. When off, display is always lit.
    - ii. **Pause** - Turns pause mode on or off. When on, Pause lasts 5 minutes.
    - iii. **Maintenance** – Reset odometer reading.
    - iv. **Units** - Set display to English or Metric readings
    - v. **Grade Return** (GS Mode) - Returns the elevation to lowest setting when pause is pressed
    - vi. **Beep** – Turns the speaker (beep sound) on or off.
  - 4) **Security** – Sets the Child Lock function. This function locks out the keypad until a pre-determined key sequence is pressed. When “Child Lock” is on, at the time power is on and before idle mode, MW will displays “**CONSOLE LOCKED**” you must press numeric key 0 and Enter at the same time to unlock console and return to idle mode.
- 5) Press **STOP** key to exit and return idle mode.

## Setting mileage lock:

- 1) Remove the safety key, press and hold numeric keys **1, 2, 3** at the same time then return the safety key to enter setting function.
- 2) Message window will display “**LOCK SETTING = ON/OFF**”.
- 3) Press **FAST/SLOW/UP/DOWN** keys to set On or Off then press **ENTER**.
- 4) If Off is set, it returns to idle mode. If On is set, it enters code setting procedure.
- 5) Now message window will display “**PASSWORD= XXXX**”. Use numeric keys in order to set a 4-digit security code. Press **ENTER** when complete.
- 6) Enter the code again to confirm. Press Enter when complete.
- 7) Now message window will show “**MILEAGE XXX Km**”. Use **UP/DOWN** or **FAST/SLOW** keys to set the required mileage. Press **ENTER** when complete. Now MW window will show “**Lock Setting OK**” and return to idle mode.
- 8) To unlock, press and hold numeric keys 1, 2, 3 at the same time to enter unlocking function.

END

# Parts List

#	Description	QTY
1	Main Frame	1
2	Incline Bracket	1
3	Interface Mounting Bracket, Left	1
4	Interface Mounting Bracket, Right	1
5	Console Support	1
6	Deck Cross Brace A	2
7	Deck Cross Brace B	1
8	Belt Guide Right	1
9	Belt Guide Left	1
10	Front Roller Assembly W/Pulley	1
11	Rear Roller Assembly	1
12	Running Deck	1
13	Running Belt	1
14	Cushion A	2
15	Cushion B	4
16	Motor Drive Belt	1
17	122 × 39 × 1390m/m_Aluminum Step Rail	2
18	125 × 29 × 1390m/m_Aluminum Step Rail	2
19	Hall Sensor Mounting Bracket	1
20	Transportation Wheel	4
21	Leveling Glide	2
22	Rubber Stop, Incline	2
23	Emergency Switch	1
24	Front Cover	1
25	Motor Top Cover	1
26	Motor Base Cap (L)	1
27	Motor Base Cap (R)	1
28	Console Assembly	1
29	Console Top Cover	1
30	Console Bottom Cover	1
31	Beverage Holder (L)	1
32	Beverage Holder (R)	1
33	Left Upright	1

URANCE®

by *Body-Solid*

# Parts List

#	Description	QTY
34	Right Upright	1
35	Ground Wire	1
36	Touch-Pad-Button Board	1
37	900m/m_Handpulse W/Cable Assembly A	1
38	900m/m_Handpulse W/Cable Assembly B	1
39	Handpulse Wire (Upper)	1
40	Handpulse Wire (Lower)	1
41	700m/m_Computer Cable (Upper)	1
42	1700m/m_Computer Cable (Lower)	1
43	700m/m_Pad/Backlit Cable	1
44	Toggle switch Key Board	1
45	Motor Assembly	1
46	PWM Motor Controller	1
47	Step Down Transformer	1
48	Filter	1
49	300m/m_Connecting Wire, Black	1
50	Motor Compartment Fan	1
51	O ring for eliminate magnet	2
52	A.C. Input Module	1
53	300m/m_Connecting Wire, White	1
54	450m/m_Connecting Wire, Black	1
55	200m/m_Motor Compartment Fan Wire, Black	1
56	200m/m_Motor Compartment Fan wire, White	1
59	Incline Motor	1
60	Sensor W/Cable	1
63	Rear Roller End Cap, Left	1
64	Rear Roller End Cap, Right	1
65	25 × 50m/m_Square End Cap	4
66	Round End Cap	2
67	Incline Carriage Spacer	4
68	Ø10 × Ø25 × 0.8T_Nylon Washer	2

END

# Parts List

#	Description	QTY
69	Sensor Rack	1
70	Motor Cover Anchor	2
83	450m/m_Connecting Wire, White	1
98	Retaining Plate	2
99	Power Line Cord	1
100	5 × 20m/m_Tapping Screw	21
101	Ø18 × Ø19 × 41L_Carriage Bolt	2
102	M8 × 1.25 × 12L_Hex Head Bolt	2
103	3/8"-16 × 25L_Hex Head Bolt	4
104	Ø8.5 × 26 × 2.0T_Flat Washer	2
105	M10 × 65L Hex Head Bolt	1
106	M10 × 50L Hex Head Bolt	1
107	Ø10 × 1.5T_Split Washer	6
108	Ø10 × Ø19 × 1.5T_Flat Washer	8
109	M10 × 8.0T_Nylon Lock Nut	2
110	Ø10 × Ø24 × 2T_Nylon Washer	2
111	3/8"-16 × 1-1/2"_Socket Head Cap Bolt	4
112	3/8" × 2-1/2"_Hex Head Bolt	1
113	3/8"-16 × 2"_Socket Head Cap Bolt	1
114	Ø10 × Ø14 × 14L_Isolation Bushing	5
115	13 × 35 × 5T_Nylon Washer	9
116	Ø3/8" × 35 × 2T_Flat Washer	11
117	3/8" × 16.5 × 2.0T × 4H_Lock Washer	17
118	3/8" × 7T_Nylon Lock Nut	2
119	M8 × 1.25 × 40L_Socket Head Cap Bolt	6
120	Ø8 × 1.5T_Lock Washer	22
121	Ø8 × 16 × 1T_Flat Washer	22
122	M8 × 1.25 × 90L_Socket Head Cap Bolt	8
123	M8 × 1.25 × 55L_Hex Head Bolt	8
124	M8 × 1.25 × 6.5T_Nut	16

URANCE®

by *Body-Solid*

# Parts List

#	Description	QTY
125	Ø3/8" × 25 × 2T_Flat Washer	10
126	M10 × 1.5 × 40L_Socket Head Cap Bolt	1
127	M10 × 1.5 × 80L_Socket Head Cap Bolt	1
128	M10 × 1.5 × 100L_Socket Head Cap Bolt	2
129	M8 × 1.25 × 55L_Flat Head Countersink Bolt	6
130	M8 × 1.25 × 35L_Flat Head Countersink Bolt	2
131	3 × 50L_Phillips Head Screw	4
132	3 × 5T_Nylon Lock Nut	4
133	M5 × 20L_Phillips Head Screw	2
134	M5 × 12L_Phillips Head Screw	15
135	M5_Nylon Lock Nut	2
136	3.5 × 12L_Tapping Screw	2
137	M5 × 1.5T_Tapping Screw	2
138	M5 × 1.5T_Split Washer	6
139	M5_Star Washer	3
140	3 × 20L_Tapping Screw	4
141	M5 × 12L_Tapping Screw	6
142	3.5 × 12L_Sheet Metal Screw	19
144	3/8"-16 × 3"_Button Head Socket Bolt	6
145	3/8"-16 × 3/4"_Button Head Socket Bolt	6
146	M8 × 1.25 × 12L_Socket Head Cap Bolt	6
147	Phillips Head Screw Driver	1
148	8m/m_L Allen Wrench	1
149	3/8" L Allen Wrench	1
150	Ending Tape	1
151	Isolation Pad	12
152	2.3 × 6L_Sheet Metal Screw	8
157	M5 × 12L_Phillips Head Screw	4
159	3 × 10L_Sheet Metal Screw	1



END

# Exploded View Diagram

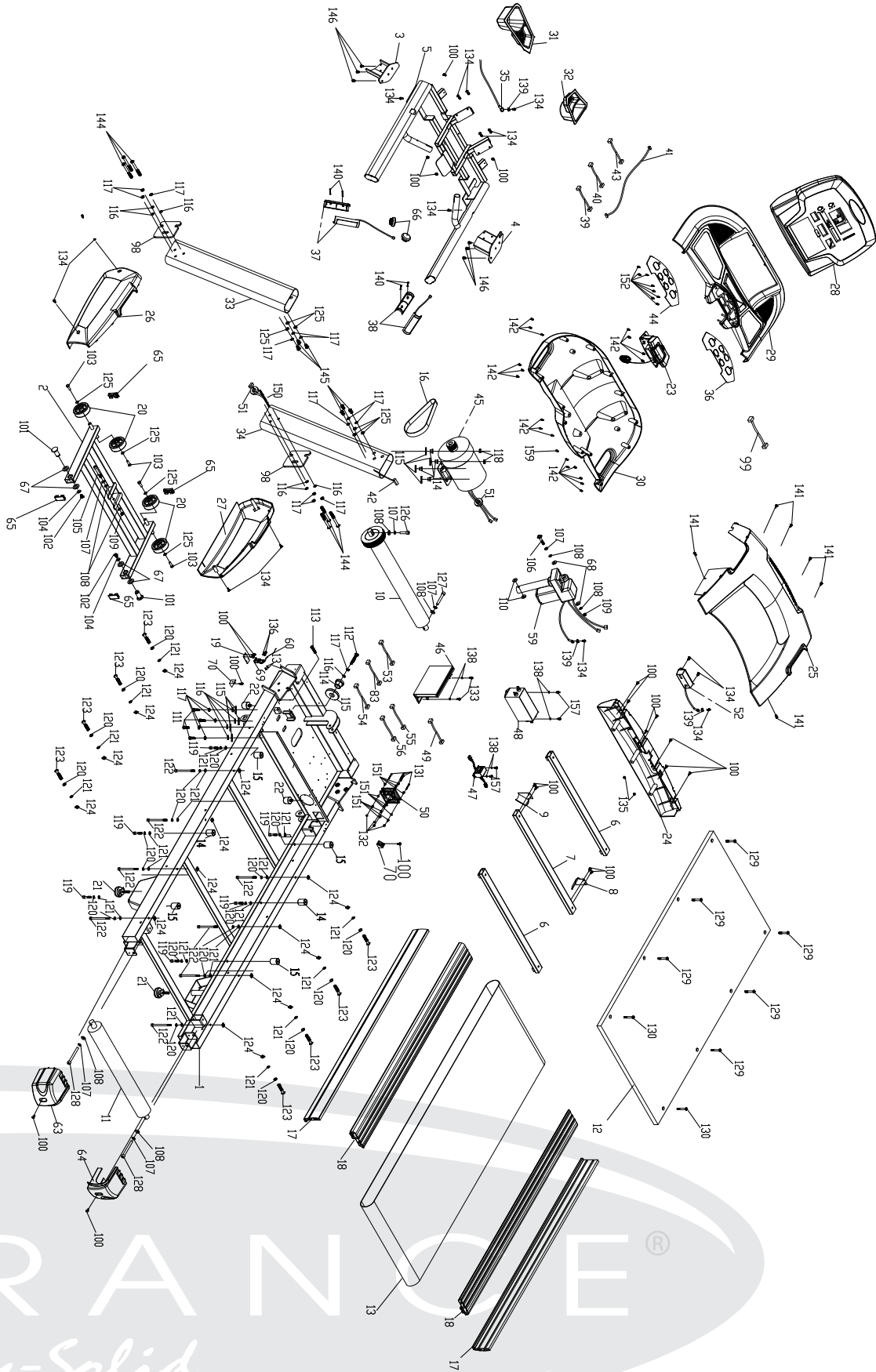

URANCE<sup>®</sup>  
by Body-Solid

