

SOLE[™]
FITNESS

***OWNER'S MANUAL
F63 Treadmill***

*Please carefully read this entire manual
before operating your new treadmill.*

ATTENTION: *Before returning your Sole product to any retailer, or if you require any assistance with assembly or technical support please call us first for assistance at 866-780-7653. Thank you for your Sole purchase.*

TABLE OF CONTENTS

Product Registration	1
Important Safety Instructions	2
Important Electrical Information	3
Important Operation Instructions	4
Assembly instructions	5
Folding Instructions	12
Transport Instructions	12
Operation of Your New Treadmill	13
Bluetooth® Connectivity	16
Charging Function	17
Programmable Features	18
General Maintenance	26
Service Checklist - Diagnosis Guide	29
Manufacturer's Limited Warranty	30



WARNING: This product can expose you to chemicals including Toluene and Acrylamide which are known to the State of California to cause Cancer and birth defects or other reproductive harm. For more information, go to www.P65Warnings.ca.gov

Before returning your Sole product to any retailer, or if you require any assistance with assembly or technical support please call us first for assistance at 866-780-7653. Thank you for your Sole purchase.

SOLE

FITNESS

CONGRATULATIONS ON YOUR NEW TREADMILL AND WELCOME TO THE SOLE FAMILY!

Thank you for your purchase of this quality treadmill from **SOLE**. Your new treadmill has been manufactured by one of the leading fitness manufacturers in the world and is backed by one of the most comprehensive warranties available. **SOLE** will do all we can to make your ownership experience as pleasant as possible for many years to come.

If there is a question as to where to obtain service, contact our service department at **866-780-7653**.

Please take a moment at this time to record below the name of the dealer, their telephone number, and the date of purchase for easy contact in the future. We appreciate your confidence in **SOLE** and we will always remember that you are the reason that we are in business. Please complete and mail your registration card today and enjoy your new treadmill.

Yours in Health,
SOLE Fitness

Name of Dealer _____

Telephone Number of Dealer _____

Purchase Date _____

PRODUCT REGISTRATION

RECORD YOUR SERIAL NUMBER

Please record the Serial Number of this fitness product in the space provided below.

Serial Number _____



REGISTER YOUR PURCHASE

The self-addressed product registration card must be completed in full and returned to **SOLE**.

You can also go to www.soletreadmills.com under the support tab to register online.

IMPORTANT SAFETY INSTRUCTIONS

WARNING - Read all instructions before using this appliance.

DANGER - To reduce the risk of electric shock disconnect your SOLE treadmill from the electrical outlet prior to cleaning and/or service work.

WARNING - To reduce the risk of burns, fire, electric shock, or injury to persons, install the treadmill on a flat level surface with access to a 120-volt, 15-amp grounded outlet with only the treadmill plugged into the circuit.

DO NOT USE AN EXTENSION CORD UNLESS IT IS A 14AWG OR BETTER, WITH ONLY ONE OUTLET ON THE END: DO NOT ATTEMPT TO DISABLE THE GROUNDED PLUG BY USING IMPROPER ADAPTERS, OR IN ANY WAY MODIFY THE CORD SET.

A serious shock or fire hazard may result along with computer malfunctions. See Grounding Instructions, page 3.

- Do not operate treadmill on deeply padded, plush or shag carpet. Damage to both carpet and treadmill may result.
- Do not block the rear of the treadmill. Provide a minimum of 3 1/2 feet clearance between the rear of the treadmill and any fixed object.
- Keep children under the age of 13 away from this machine. There are obvious pinch points and other caution areas that can cause harm.
- Keep hands away from all moving parts.
- Never operate the treadmill if it has a damaged cord or plug. If the treadmill is not working properly, call your dealer.
- Keep the cord away from heated surfaces.
- Do not operate where aerosol spray products are being used or where oxygen is being administered. Sparks from the motor may ignite a highly gaseous environment.
- Never drop or insert any object into any openings.
- Do not use outdoors.
- To disconnect, turn all controls to the off position, remove tether cord, then remove the plug from the outlet.
- Do not attempt to use your treadmill for any purpose other than for the purpose it is intended.
- The pulse sensors are not medical devices. Various factors, including the user's movement, may affect the accuracy of heart rate readings. The pulse sensors are intended only as exercise aids in determining heart rate trends in general.
- Use handrails provided; they are for your safety.
- Wear proper shoes. High heels, dress shoes, sandals or bare feet are not suitable for use on your treadmill. Quality athletic shoes are recommended to avoid leg fatigue.
- This appliance is not intended for use by persons with reduced physical, sensory or mental capabilities, or lack of experience and knowledge, unless they have been given supervision or instruction concerning use of the appliance by a person responsible for their safety.

**Remove tether cord after use to prevent unauthorized treadmill operation.
SAVE THESE INSTRUCTIONS - THINK SAFETY!**

IMPORTANT ELECTRICAL INSTRUCTIONS

WARNING!

Route the power cord away from any moving part of the treadmill including the elevation mechanism and transport wheels.

NEVER remove any cover without first disconnecting AC power.

If voltage varies by ten percent (10%) or more, the performance of your treadmill may be affected. Such conditions are not covered under your warranty. If you suspect the voltage is low, contact your local power company or a licensed electrician for proper testing.

NEVER expose this treadmill to rain or moisture. This product is NOT designed for use outdoors, near a pool or spa, or in any other high humidity environment. The maximum operating temperature specification is 40 degrees C, and humidity is 95% non-condensing (no water drops forming on surfaces).

Circuit Breakers: Avoid AFCI/GFCI circuit breakers if possible. These breakers may trip occasionally during exercise because of the high inrush currents of the treadmill drive electronics and motor. This is an issue that affects all treadmill brands.

New laws in your area may require these breakers. If you do have these breakers and outlets in your home, and are experiencing nuisance tripping, you should check if there are any other devices plugged into the same circuit. Some examples of devices that may also cause tripping are fluorescent lights with electronic ballasts, coffee maker, space heater, hair drier. Optimally the treadmill should be the only device plugged into the circuit.

Our treadmills have surge suppressors built in to help avoid nuisance tripping. We have tested several AFCI/GFCI breakers and outlets with our products. Brands we have tested are: Eaton (Cutler Hammer Series), Leviton (Smart lock pro) and Schneider Electric (Canadian home series). These breakers do not trip in our testing, when connected to our treadmills, as long as no other devices are plugged into the same circuit.

GROUNDING INSTRUCTIONS

This product must be grounded. If the treadmill should malfunction or breakdown, grounding provides a path of least resistance for electric current, reducing the risk of electric shock. This product is equipped with a cord having an equipment-grounding plug. The plug must be plugged into an appropriate outlet that is properly installed and grounded in accordance with all local codes and ordinances.

DANGER - Improper connection of the equipment-grounding conductor can result in a risk of electric shock. Check with a qualified electrician or serviceman if you are in doubt as to whether the product is properly grounded. Do not modify the plug provided with the product if it will not fit the outlet; have a proper outlet installed by a qualified electrician.

This product is for use on a nominal 120-volt circuit, and has a grounding plug that looks like the plug illustrated below. A temporary adapter that looks like the adapter illustrated below may be used to connect this plug to a 2-pole receptacle as shown below if a properly grounded outlet is not available. The temporary adapter should be used only until a properly grounded outlet, (shown below) can be installed by a qualified electrician. The green colored rigid ear lug, or the like, extending from the adapter, must be connected to a permanent ground such as a properly grounded outlet box cover. Whenever the adapter is used, it must be held in place by a metal screw.

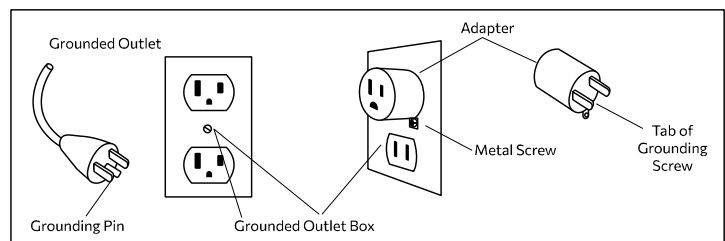

IMPORTANT OPERATION INSTRUCTIONS

- **NEVER** operate this treadmill without reading and completely understanding the results of any operational change you request from the computer.
- Understand that changes in speed and incline do not occur immediately. Set your desired speed on the computer console and release the adjustment key. The computer will obey the command gradually.
- **NEVER** use your treadmill during an electrical storm. Surges may occur in your household power supply that could damage treadmill components. Unplug the treadmill during an electrical storm as a precaution.
- Use caution while participating in other activities while walking on your treadmill; such as watching television, reading, etc. These distractions may cause you to lose balance or stray from walking in the center of the belt; which may result in serious injury.
- **NEVER** mount or dismount the treadmill while the belt is moving. **SOLE** treadmills start at a very low speed and it is unnecessary to straddle the belt during start up. Simply standing on the belt during slow acceleration is proper after you have learned to operate the unit.
- Always hold on to a handrail or hand bar while making control changes (incline, speed, etc.).
- Do not use excessive pressure on console control keys. They are precision set to function properly with little finger pressure. Pushing harder is not going to make the unit go faster or slower. If you feel the buttons are not functioning properly with normal pressure contact your **SOLE** dealer.

IMPORTANT SAFETY INSTRUCTIONS

A safety tether cord is provided with this unit and should be used at all times. It is for your safety should you fall or move too far back on the tread-belt. Pulling this safety tether cord will stop tread-belt movement.

To Use:

1. Place the safety key into position on the console control head. Your treadmill will not start and operate without this. Removing the safety key also secures the treadmill from unauthorized use.
2. Fasten the plastic clip onto your clothing securely to assure good holding power.
Note: *The clip should be attached securely to make certain it does not come off. Be familiar with its function and limitations. The treadmill will stop, depending on speed, with a one to two step coast anytime the safety key is pulled off the console. Use the red **Stop** switch in normal operation.*
3. If the console displays "SAFE. Please replace the key to Operate", put the Safety key back to continue using the treadmill.

IMPORTANT SAFETY INSTRUCTIONS

READ BEFORE UNPACKING YOUR FOLDING TREADMILL

Serious injury could occur if this folding treadmill is not unpacked properly.

There is a deck restraint SHIPPING strap installed around the treadmill base that prevent the treadmill from unfolding accidentally during shipping. If this strap is not removed properly the treadmill could spring open unexpectedly and cause injury if someone is standing near the treadmill when the strap is removed.

To ensure your personal safety during removal of the shipping strap please make sure the treadmill is positioned flat on the ground, in the orientation it would be in if you were using the treadmill. Do not tilt the treadmill up on its side while removing the shipping strap: this could cause the treadmill's folding mechanism to spring open. To remove the strap, pull up on the strap and cut it with a pair of scissors.

There is a safety pin locked on the treadmill base that prevents the treadmill from unfolding accidentally during shipping. This safety pin has to be removed before powering on or using the incline function to avoid any damages to the machine. When removing the safety pin, pull it away from the treadmill base completely.

F63 ASSEMBLY INSTRUCTIONS

Scan Here for Assembly Video



F63 ASSEMBLY PACK CHECKLIST

2 HARDWARE STEP 2

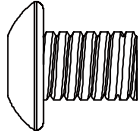

#83. 5/16" × 1/2" Button Head Socket Bolt (2 pcs)



#64. Ø8 × 1.5T Split Washer (10 pcs)

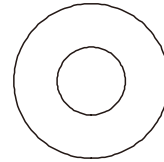

#59. Ø5/16" × Ø18 × 1.5T Flat Washer (10 pcs)

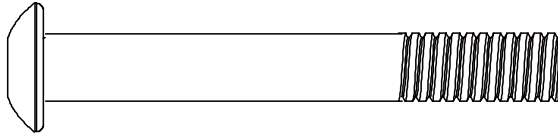

#93. 5/16" × UNC18 × 3" Button Head Socket Bolt (8 pcs)

3 HARDWARE STEP 3

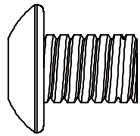

#83. 5/16" × 1/2" Button Head Socket Bolt (4 pcs)



#64. Ø8 × 1.5T Split Washer (4 pcs)

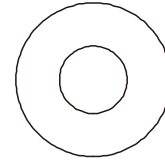

#59. Ø5/16" × Ø18 × 1.5T Flat Washer (4 pcs)

4 HARDWARE STEP 4

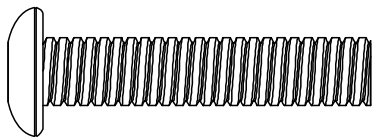

#94. 5/16" × 1-1/2" Button Head Socket Bolt (2 pcs)

5 HARDWARE STEP 5

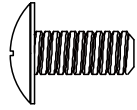

#87. M5 x 10mm_Phillips Head Screw (6 pcs)

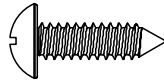

#95. 3.5 x 12mm_Sheet Metal Screw (4 pcs)

7 HARDWARE STEP 7

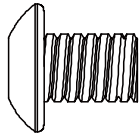

#83. 5/16" x 1/2" Button Head Socket Bolt (2 pcs)



#64. Ø8 x 1.5T_Split Washer (2 pcs)

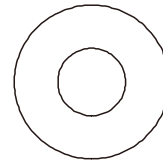

#59. Ø5/16" x Ø18 x 1.5T_Flat Washer (2 pcs)

ASSEMBLY TOOLS

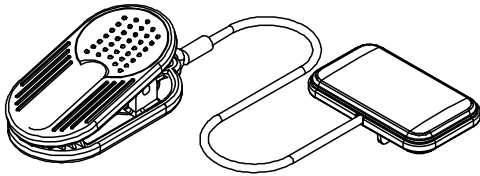

#20. Safety Key



#112. End Cap

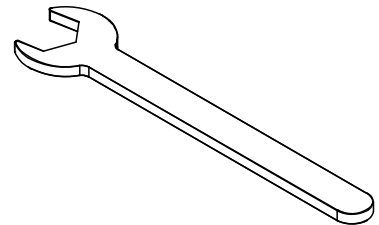

#96. 13mm_Wrench

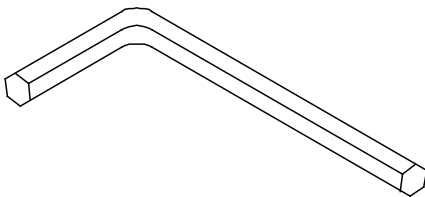

#98. M6 L Allen Wrench

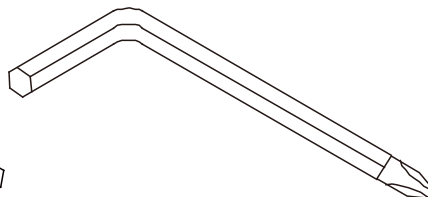

#97. Combination M5 Allen Wrench & Phillips Head Screw Driver

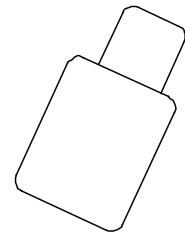

#116. Lubricant

F63 ASSEMBLY INSTRUCTIONS

1 ASSEMBLY STEP 1

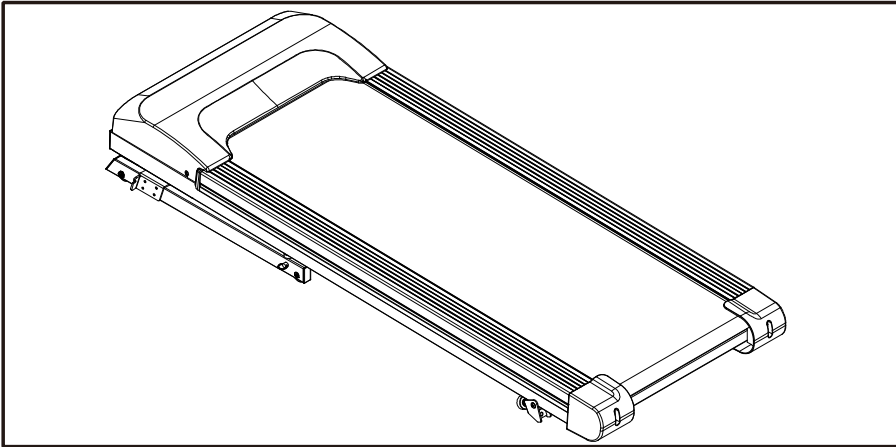

1. Remove the treadmill from the carton and position it aside on a smooth, leveled floor. The rear should be at least 3' from any wall. You must remove the plastic wrap and Styrofoam from beneath the unit before removing the Velcro belt. **Tilting the unit sideways after removing the belt may cause the unit to fold and bounce upwards. This can cause serious injury.**

2 ASSEMBLY STEP 2

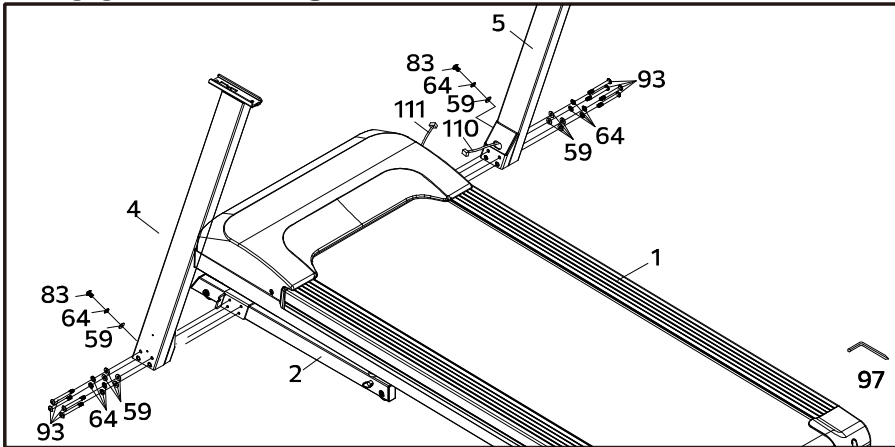

1. Remove the treadmill from the carton and position it aside on a smooth, leveled floor. Connect Computer Cable (Lower) (111) to the Computer Cable (Middle) (110) and then organize the Computer Cable to the Right Upright (5).
2. Install the Left Upright (4) and Right Upright (5) onto the Frame Base (2) with Button Head Socket Bolt (93) 8pcs, Split Washer (64) 8pcs, and Flat Washer (59) 8pcs by using M5_Allen Wrench Head Screw Wrench (97).
3. Fix the Left Upright (4) and Right Upright (5) with Button Head Socket Bolt (83) 2pcs, Split Washer (64) 2pcs, and Flat Washer (59) 2pcs by using Allen Wrench Head Screw Wrench (97). Do not tighten the bolts completely until Step 6 is finished.

NOTE: Please DON'T Tighten All Screws.

HARDWARE STEP 2

- #83. 5/16" x 1/2" Button Head Socket Bolt (2 pcs)
- #64. Ø8 x 1.5T_Split Washer (10 pcs)
- #59. Ø5/16" x Ø18 x 1.5T_Flat Washer (10 pcs)
- #93. 5/16" x UNC18 x 3" Button Head Socket Bolt (8 pcs)

3 ASSEMBLY STEP 3

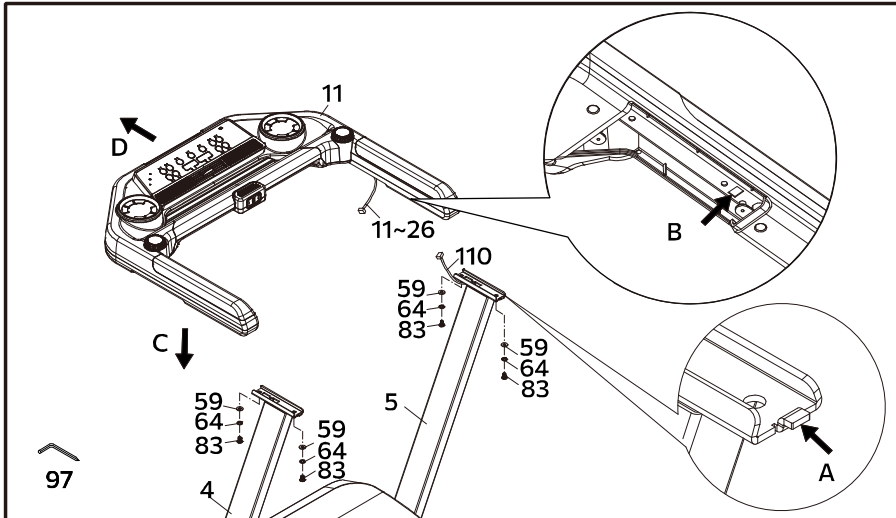

HARDWARE STEP 3

- #83. 5/16" x 1/2" Button Head Socket Bolt (4 pcs)
- #64. Ø8 x 1.5T Split Washer (4 pcs)
- #59. Ø5/16" x Ø18 x 1.5T Flat Washer (4 pcs)

1. Connect Computer Cable (Middle) (110) to the Computer Cable (Upper) (11~26) and then organize the Computer Cable to the Right Upright (5).
2. Align square hole B (below view) of the Console Assembly (11) with the L-shaped hook plates A on the Left Upright (4) and Right Upright (5). Install in direction C. After the Console Assembly (11) is fully seated and flush with the Left Upright (4) and Right Upright (5), push it further in direction D. Fix the console assembly (11) onto the Left Upright (4) and Right Upright (5) with Button Head Socket Bolt (83) 4pcs, Split Washer (64) 4pcs, and Flat Washer (59) 4pcs by using M5_Allen Wrench Head Screw Wrench (97).

NOTE: Please DON'T Tighten All Screws.

4 ASSEMBLY STEP 4

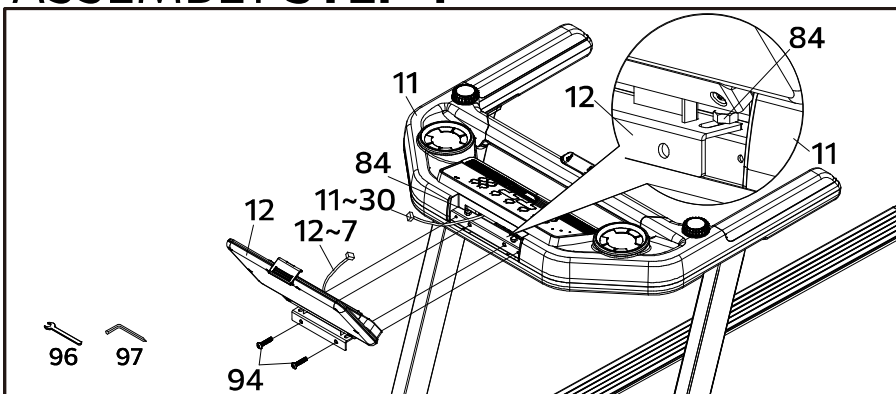

HARDWARE STEP 4

- #94. 5/16" x 1-1/2" Button Head Socket Bolt (2 pcs)

1. Connect Connecting Wire (11~30) to the Connecting Wire (12~7) and then organize wire to the Right Console assembly (11).
2. Place lower edge of the Pad Top Cover Assembly (12) against the upper edge of the console assembly (11). Then slide it forward to the Hex Head Bolt (84) 2pcs as shown in Figure 1.

3. Install the Pad Top Cover Assembly (12) on the Console assembly (11) with Button Head Socket Bolt (94) 2pcs by using Allen Wrench Head Screw Wrench (97).
4. Fix the Pad Top Cover Assembly (12) on the Console assembly (11) with Hex Head Bolt (84) 2pcs by using Wrench (96).

NOTE: After above assembly, tighten the screws in place.

5 ASSEMBLY STEP 5

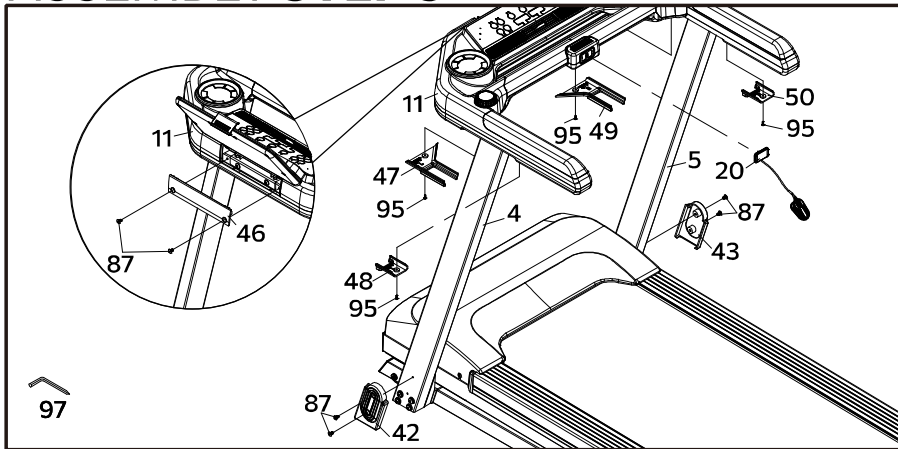

HARDWARE STEP 5

- #87. M5 × 10mm_Phillips Head Screw (6 pcs)
- #95. 3.5 × 12mm_Sheet Metal Screw (4 pcs)

1. Install Front Console Mast Cover (L) (47), Rear Console Mast Cover (L) (48), Front Console Mast Cover (R) (49), Rear Console Mast Cover (R) (50) onto the Console assembly (11) with Sheet Metal Screw (95) 4pcs by using M5_Allen Wrench Head Screw Wrench (97).
2. Install Frame Base Cover (L) (42), and Frame Base Cover (R) (43) onto the Left Upright (4) and Right Upright (5) with Phillips Head Screw (87) 4pcs by using M5_Allen Wrench Head Screw Wrench (97).
3. Install Console Outer Cover Mast Cover (46) onto the Console assembly (11) with Phillips Head Screw (87) 2pcs by using Allen Wrench Head Screw Wrench (97).
4. Insert Square Safety Key (20) to the Console assembly (11).

6 ASSEMBLY STEP 6

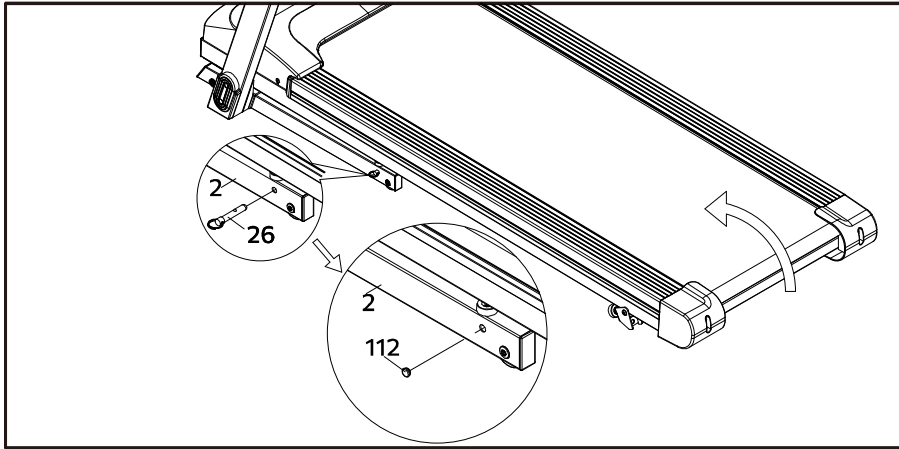

1. Remove Locking Pin Assembly (**26**) from the Frame Base (**2**) and then plug End Cap (**112**) into the hole of the Frame Base (**2**).
2. Lift the running deck to fold it.

7 ASSEMBLY STEP 7

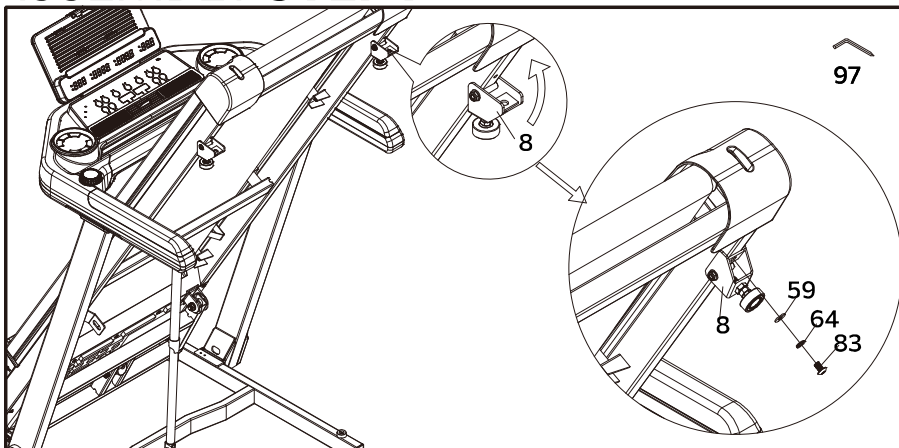

HARDWARE STEP 7

- #83. 5/16" × 1/2" Button Head Socket Bolt (2 pc)
- #64. Ø8 × 1.5T Split Washer (2 pc)
- #59. Ø5/16" × Ø18 × 1.5T Flat Washer (2 pc)

1. Rotate the foot pad (**8**) upward until it is against the running deck. Fix the foot pad (**8**) on the running deck with Button Head Socket Bolt (**83**)1pcs, Split Washer (**64**)1pcs, and Flat Washer (**59**)1pcs by using M5 Allen Wrench Head Screw Wrench (**97**). Install the foot pad (**8**) in the same way as on the right side to install the foot pad (**8**) on the left side.

FOLDING INSTRUCTIONS

Do not attempt to move the unit unless it is in the folded and locked position. Be sure the power cord is secured to avoid possible damage. Use both handrails to maneuver the unit to the desired position.

■ TO FOLD THE TREADMILL

Make certain that the treadmill is at minimum incline. Lift the treadmill's running deck until it is secured by the cylinder in the center back of the base.

■ TO UNFOLD THE TREADMILL

Using your foot firmly push against the cylinder to release the folding mechanism.

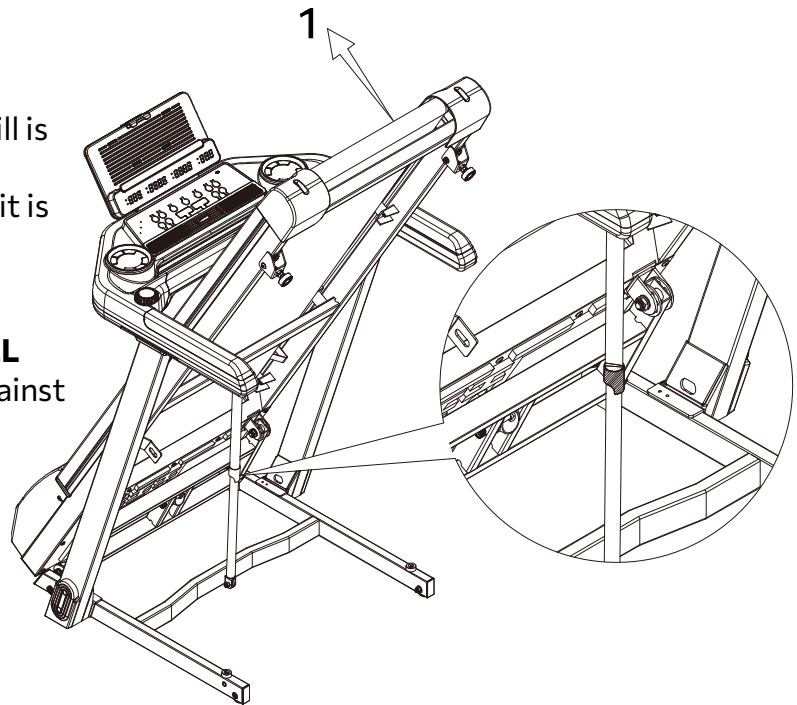

TRANSPORTATION INSTRUCTIONS

The treadmill is equipped with transport wheels that are engaged when the treadmill is folded.

After folding simply roll the treadmill away.

OPERATION OF YOUR TREADMILL

GETTING FAMILIAR WITH THE CONTROL PANEL

F63 CONSOLE



GETTING STARTED

Power the treadmill on by plugging it into an appropriate wall outlet, then turn on the power switch located at the front of the treadmill below the motor hood. Ensure that the **Safety Key** is installed, as the treadmill will not power on without it.



When the power is turned on, The speed window displays the current version of the software. Then the **Time** and **distance Windows** will display Odometer readings for a short time. **Time Window** will show how many hours the treadmill has been in use and the **distance Window** will show how many miles (or Kilometers if the treadmill is set to metric readings) the treadmill has gone. The treadmill will then enter idle mode, which is the starting point for operation.

START OPERATION

1. Attach the **Safety Key** to wake the display up, if it's not already on.
2. Press the **Start** key to begin belt movement. Use the speed knob button to adjust to the desired speed. You may also use the speed keys 3, 6, 9, 12 to adjust the speed.
3. To slow down the tread belt, use the speed knob to adjust it to the desired speed. You may also press the speed adjust keys, 3 through 12.
4. To stop the tread-belt, press **Stop** key or pull away **Safety Key**.



PAUSE/STOP/RESET FEATURE

1. When the treadmill is running, the pause feature may be utilized by pressing the red **Stop** key once. This will slowly decelerate the tread-belt to a stop. The incline will go to zero percent. The **Time**, **Distance** and **Calorie** readings will hold while the unit is in the pause mode. After 5 minutes the display will reset and return to the start up screen.
2. To resume your exercise, while in Pause mode, press the **Start** key. The speed and incline will return to their previous settings.
 - Pause is executed when the **Stop** button is pressed once. If the **Stop** button is pressed for the second time, the program will end and a workout summary will be displayed. If the **Stop** button is pressed for the third time, the console will return to the idle mode (start up) screen. If the **Stop** button is held down for more than 3 seconds, the console will reset.

INCLINE FEATURE

- Incline may be adjusted anytime after belt movement.
- Use the Incline knob to adjust the keys to achieve the effect you want. You may also choose a more rapid increase / decrease by selecting desired key 0, 5, 10, 15, on the left hand side of console (incline).
- The **Incline Window** display will indicate incline position as adjustments are made.

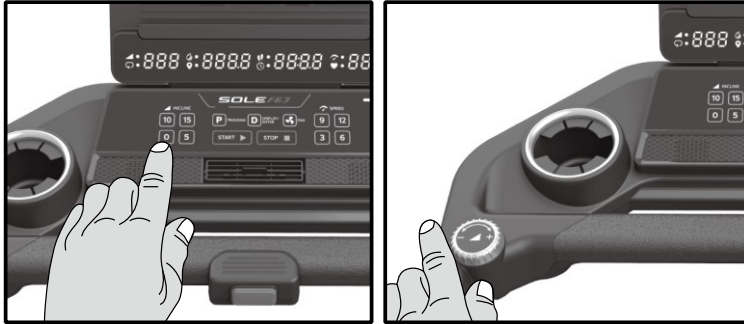

CALORIE DISPLAY

Displays the cumulative calories burned at any given time during your workout.

Note: *This is only a rough guide used for comparison of different exercise sessions, which cannot be used for medical purposes.*

1/4 MILE TRACK

The number of laps you complete are accumulated in the lap counter, which is viewed in the **LAPS Window**.

PULSE FEATURE

The **Pulse (Heart Rate) Window** will display your current heart rate in beats per minute during the workout. You must wear the wireless Bluetooth chest strap to show your pulse. The pulse value will display anytime the upper display is receiving a pulse signal.

TURNING OFF TREADMILL

1. The display will automatically turn off, by going into sleep, after 15 minutes of inactivity when in the Stop mode. Almost all power for the treadmill will be off except for some circuits that are needed to detect if any key is pressed, indicating the console should “wake up”. When the console is “asleep” the treadmill draws very little power, for about as much as a television turned off.
2. Removing the **Safety Key** is similar to entering “sleep” mode. Turning off the main power switch in the front of the treadmill will completely remove any power.

ATTENTION

SLEEP MODE Your console comes in "Sleep mode" with different features by choice:

ON The unit goes energy-saving state after 15 minutes of inactivity.

OFF The console will stay lit while the power is on.

RETAIL The console will run the demo video after 3 minutes of inactivity.

On LED displays, Hold the Stop and Display keys for 5 seconds to switch between ON and OFF.

On LCD displays, press and hold the Stop, Enter, and Display keys for 5 seconds to switch between ON and OFF.

On TFT displays, click “Sleep Mode” under Settings to switch among three features.

New SOLE + App to be used in conjunction with select Apple & Android devices!

In order to help you achieve your exercise goals, Sole has added an exciting new feature to this product. Your new exercise machine comes equipped with a Bluetooth® transceiver that will allow it to interact with compatible iOS and Android smartphones or tablet computers via the SOLE+ App.

Just download the free SOLE+ App from the Apple Store or Google Play, and follow the instructions in the App to sync with your exercise machine.

The Sole+ App also allows you to sync your workout data with one of many fitness cloud sites we support: Apple Health, Google Health Connect, Strava, or MapMyFitness, with more to come.

Syncing the App with your exercise machine:

After downloading the App, make sure Bluetooth® is enabled on your device, then tap the icon at the top right corner to search for Sole equipment.

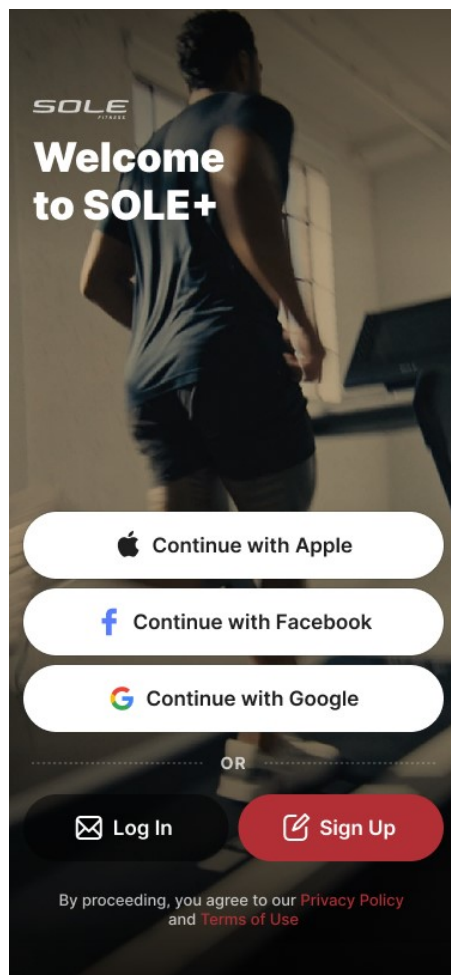

After the equipment is detected, tap Connect. When the App and equipment are synced, Bluetooth® icon on the equipment's console will light up. You may now start using your new Sole product!

The exercise equipment can also play music wirelessly via Bluetooth. Turn on your mobile phone or tablet's Bluetooth function. Search for the name "BT-Speaker" in your device's Bluetooth menu. Tap to connect. Now your device can transmit music to the exercise equipment.

Charge Portable Devices with USB port

USB Port Charging function:

Charge your personal device during your workout using the fitness equipment's on-console type-c USB port.

To charge your mobile electronics make sure the fitness equipment power is on.

Step 1: Connect your type-c USB charging cable to the USB Power Port and to your device.

Step 2: Check to make sure your device icon indicates it is charging.



NOTE :

- USB charging cable is not included, make sure compatible USB charging cable is being used.
- Your device “charging” icon may or may not indicate it is charging. Depending on the amount of current your particular device requires for charging the icon may not be on but your device is still charging, but possibly at a lower charge rate.
- The USB port on the console is capable of powering USB devices. It provides up to 5Vdc/1.5 amp of power. You will not be able to save your workout data to a USB via this port; it is used for charging purposes only.

PROGRAMMABLE FEATURES

The F63 / have Eight built-in programs: one Manual program (P1) , five preset profiles (P2-P6), two Heart Rate programs (H1 & H2).

MANUAL PROGRAM

1. Press the **Program** keys to view the programs on the screen then press the Display/**Enter** key to select the program you would like to perform. You can just press the **Start** key to begin the program using the preset program values for age, weight and other program specific information.
2. If Display/**Enter** was pressed, the **Incline Window** will display **Age**. You may use the speed knob key to adjust your age. After adjusting press the Display/**Enter** key.
***Note:** You may press **Start** at any time during the programming to start the program with the information you've already input.*
3. The **Incline Window** will now be displaying a value, which is your body weight. Entering the correct body weight will affect the calorie count. You may use the speed knob key to adjust, then press Display/**Enter**.
***Calorie Display Note:** No exercise machine can give you an exact calorie count because there are too many factors which determine exact calorie burn for a particular person. Even if someone is the exact same body weight, age and height, their calorie burn may be very different than yours. The **Calorie** display is to be used as a reference only to monitor improvement from workout to workout.*
4. The **Time Window** will now be displaying a value, which is total workout time desired. You may use the speed knob key to adjust, and then press Display/**Enter**.
5. Press **Start** to begin the program.

SELECTING A PROGRAM

1. Press the **Program** keys to view the programs on the screen then press the Display/**Enter** key to select the program you would like to perform. P2-Hill, P3-Fat Burn, P4-Cardio, P5-Strength, P6-Interval. You can just press the **Start** key to begin the program using the preset program values for age, weight and other program specific information.
2. If Display/**Enter** was pressed, the **Incline Window** will display **Age**. You may use the speed knob key to adjust your age. After adjusting press the Display/**Enter** key.
***Note:** You may press **Start** at any time during the programming to start the program with the information you've already input.*
3. The **Incline Window** will now be displaying a value, which is your body weight. Entering the correct body weight will affect the calorie count. You may use the speed knob key to adjust, then press Display/**Enter**.
***Calorie Display Note:** No exercise machine can give you an exact calorie count because there are too many factors which determine exact calorie burn for a particular person. Even if someone is the exact same body weight, age and height, their calorie burn may be very different than yours. The **Calorie** display is to be used as a reference only to monitor improvement from workout to workout.*

4. The **Time Window Window** will now be displaying a value, which is total workout time desired. You may use the speed knob key to adjust, and then press Display/**Enter**.
5. The **speed Window** will display the preset max speed of the selected program. You may use the speed knob key to adjust, and then press Display/**Enter**. Each program has various speed changes throughout; this allows you to limit the highest speed the program will reach at it's peak.
6. Press **Start** to begin the program. The program will begin with a 3 minute warm-up. If you want to bypass this and go directly to the beginning of the program, press **Start** again.

program	Seg	Warm up			1	2	3	4	5	6	7	8	9	10	11	12	13	14	15	16	17	18	Cool down		
Hill	Speed %	20	30	40	50	63	75	75	75	88	75	88	88	100	75	88	75	88	88	75	63	50	40	30	20
	Incline	0	0	0	0	1	2	3	4	3	4	4	5	3	4	3	4	5	3	1	1	0	0	0	0
Fat burn	Speed %	20	30	40	50	63	63	100	100	100	100	100	100	100	100	100	100	100	88	75	63	50	40	30	20
	Incline	0	0	0	0	1	2	4	5	3	4	4	3	2	3	4	5	6	4	2	1	0	0	0	0
Cardio	Speed %	20	30	40	50	63	75	75	87.5	75	75	88	63	75	88	75	75	100	75	88	63	50	40	30	20
	Incline	0	0	0	0	1	2	3	2	2	3	1	2	3	2	2	4	2	3	1	1	0	0	0	0
Strength	Speed %	20	30	40	63	63	75	75	75	75	88	88	88	100	88	88	88	75	75	75	63	63	40	30	20
	Incline	0	0	0	0	1	2	4	6	8	7	6	5	4	3	4	5	7	7	5	1	0	0	0	0
Interval	Speed %	20	30	40	50	63	75	88	63	63	88	63	75	100	63	75	100	63	75	88	63	50	40	30	20
	Incline	0	0	0	0	1	2	3	5	2	3	6	2	3	7	2	3	8	2	3	3	0	0	0	0

HEART RATE PROGRAMMING

CAUTION!

Heart Rate programs are intended for wireless Bluetooth wearables only. You must receive a strong/steady value in the **Heart Rate Window** (See Using Wireless wearable devices section for instructions on how to use).

The **H1** program has a default level that is 60% of your projected heart rate maximum. This program is geared for individuals with fat loss as a goal. The **H2** program has a default of 80% of your projected heart rate maximum. It is geared for individuals with a goal of improving cardiovascular & lung function.

1. Select **H1** or **H2** via the **Program** keys then press **Display/Enter**.
2. The **Incline Window** will now be blinking showing user's age. Adjust and press **Display/Enter** or press **Display/Enter** to accept the default value. Adjusting **Age** will change the Target HR value.
3. The **Incline Window** will be blinking, showing the default user's bodyweight for this program. You may adjust it and press **Display/Enter** if you want or just press **Display/Enter** to accept the default value.
4. Now you are asked to adjust the **H1** or **H2** value. The default is 60% (**H1**); $(220 - \text{age} \times 0.60)$; or 80% (**H2**); $(220 - \text{age} \times 0.80)$. You may use the speed knob key to adjust and press **Display/Enter** to continue.
5. The **Time Window** will now be blinking. Adjust the time and press **Display/Enter**.
6. Now you are finished editing the settings and can begin your workout by pressing the **Start** key. You can also go back and modify your settings by pressing the **Stop** key to go back one level, or screen.
7. If you want to increase or decrease the speed at any time in the program, you can adjust it by pressing the speed knob.
8. When the program ends the **Message Window** will show a summary of your workout. The summary will be displayed for a short time then the console will return to the start-up display.
9. Press **Start** to begin program.

The program will now control the treadmill to steadily increase your heart rate to the target value. This process is automatic and could take upwards of five minutes, depending on how far your HR needs to go and what kind of physical shape you are in. People who are more fit will take longer to reach the target.

HEART RATE PROGRAMS

Before we get started, a word about Heart Rate:

The old motto, “no pain, no gain”, is a myth that has been overpowered by the benefits of exercising comfortably. A great deal of this success has been promoted by the use of heart rate monitors. With the proper use of a heart rate monitor, many people find that their usual choice of exercise intensity was either too high or too low and exercise is much more enjoyable by maintaining their heart rate in the desired benefit range.

To determine the benefit range in which you wish to train, you must first determine your Maximum Heart Rate. This can be accomplished by using the following formula: 220 minus your age. This will give you the Maximum Heart Rate (MHR) for someone of your age. To determine the effective heart rate range for specific goals you simply calculate a percentage your MHR. Your Heart rate training zone is 50% to 90% of your maximum heart rate. 60% of your MHR is the zone that burns fat while 80% is for strengthening the cardiovascular system. This 60% to 80% is the zone to stay in for maximum benefit.

For someone who is 40 years old their target heart rate zone is calculated:

$$\begin{aligned} 220 - 40 &= 180 \text{ (maximum heart rate)} \\ 180 \times 0.6 &= 108 \text{ beats per minute} \\ &\quad \text{(60\% of maximum)} \\ 180 \times 0.8 &= 144 \text{ beats per minute} \\ &\quad \text{(80\% of maximum)} \end{aligned}$$

So for a 40 year old the training zone would be 108 to 144 beats per minute.

If you enter your age during programming the console will perform this calculation automatically. Entering your age is used for the Heart Rate programs. After calculating your MHR you can decide upon which goal you would like to pursue.

The two most popular reasons for, or goals, of exercise are cardiovascular fitness (training for the heart and lungs) and weight control. The black columns on the chart above represent the MHR for a person whose age is listed at the bottom of each column. The training heart rate, for either cardiovascular fitness or weight loss, is represented by two different lines that cut diagonally through the chart. A definition of the lines' goal is in the bottom left-hand corner of the chart. If your goal is cardiovascular fitness or if it is weight loss, it can be achieved by training at 80% or 60%, respectively, of your MHR on a schedule approved by your physician. Consult your physician before participating in any exercise program.

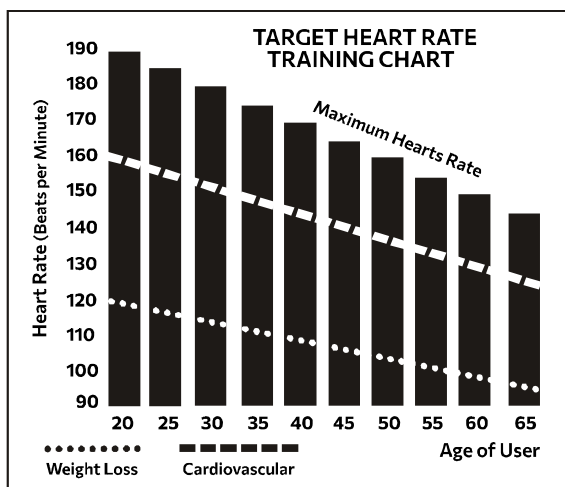

RATE OF PERCEIVED EXERTION

Heart rate is important but listening to your body also has a lot of advantages. There are more variables involved in how hard you should workout than just heart rate. Your stress level, physical health, emotional health, temperature, humidity, the time of day, the last time you ate and what you ate, all contribute to the intensity at which you should workout. If you listen to your body, it will tell you all of these things.

The rate of perceived exertion (RPE), also know as the Borg scale, was developed by Swedish physiologist G.A.V. Borg. This scale rates exercise intensity from 6 to 20 depending upon how you feel or the perception of your effort.

The scale is as follows: Rating

Perception of Effort

- 6 Minimal
- 7 Very,very light
- 8 Very,very light +
- 9 Very light
- 10 Very light +
- 11 Fairly light
- 12 Comfortable
- 13 Somewhat hard
- 14 Somewhat hard +
- 15 Hard
- 16 Hard +
- 17 Very hard
- 18 Very hard +
- 19 Very,very hard
- 20 Maximal

You can get an approximate heart rate level for each rating by simply adding a zero to each rating. For example a rating of 12 will result in an approximate heart rate of 120 beats per minute. Your RPE will vary depending up the factors discussed earlier. That is the major benefit of this type of training. If your body is strong and rested, you will feel strong and your pace will feel easier. When your body is in this condition, you are able to train harder and the RPE will support this. If you are feeling tired and sluggish, it is because your body needs a break. In this condition, your pace will feel harder. Again, this will show up in your RPE and you will train at the proper level for that day.

USING WIRELESS WEARABLE DEVICES

The exercise equipment's Bluetooth device can also be connected to the Bluetooth wearables. The Bluetooth wearables can receive signals even when the App is already in use. You can wear the Bluetooth wearables first then commence connection. While in connection, the console will show heart rate value via Bluetooth.

With the NFC reader the users wearing an Apple watch or a Samsung watch can close the watch to the NFC reader where the  shown on the panel. The fitness equipment will automatically connect the watch. Once starting workout the heart rate value of the watch can be displayed on the panel of the fitness equipment and the workout data of the fitness equipment can be display on the watch as well.

SERVICE CHECKLIST - DIAGNOSIS GUIDE

Before contacting us for aid, please review the following information. It may save you both time and expense. This list includes common problems that may not be covered under the treadmill's warranty.

Problem	Meaning	Solution/Cause
Console Showing LUBE	Reminder to check lubrication under walking deck	<ol style="list-style-type: none"> 1. Check lubrication under walking belt. Reference belt deck lubrication procedure on page 28. 2. Power the treadmill three times to reset the lube message.
Console Showing E01	Over Current Protection Treadmill overloaded, controller protection is activated.	<ol style="list-style-type: none"> 1. Exceeding the rated load leads to excessive current, the system self-protection shows the error code, and re-power recovery. 2. A certain part of the treadmill is stuck, resulting in the motor can not turn, the load is too heavy, the current is too large, the system reports an error, adjust the treadmill to restart the operation or increase the lubricating oil 3. Check whether there is a flowing sound or burning smell when the motor is running, and replace the motor 4. Replace the controller.
Console Showing E02	Hall mistake	<ol style="list-style-type: none"> 1. Motor is not connected properly or not connected to the controller. 2. Replace the motor. 3. Replace the controller.
Console Showing E03	The hardware current is too large.	<ol style="list-style-type: none"> 1. Exceeding the rated load leads to excessive current, the system self-protection shows the error code, and re-power recovery. 2. Check whether the connection between the power socket plug and the motor is loose. 3. Replace the controller.
Console Showing E04	Phase loss	<ol style="list-style-type: none"> 1. Motor is not connected properly or not connected to the controller. 2. Replace the motor. 3. Replace the controller.
Console Showing E05	undervoltage	<ol style="list-style-type: none"> 1. Check whether the input power voltage is normal. 2. Check whether the connector of the power socket is loose.
Console Showing E06	overvoltage	<ol style="list-style-type: none"> 1. Check whether the input power voltage is normal.
Console Showing E3	Incline adjustment error	<ol style="list-style-type: none"> 1. Check whether the Incline cable is properly connected. 2. Connect the Incline cable and power it on. 3. Connect the Incline wire and re-calibrate it.
Console Showing E22	The communication between the upper computer and the lower controller is incorrect	<ol style="list-style-type: none"> 1. Check whether the cable between the electronic watch and the controller is loose. 2. Check whether the controller is damaged. 3. Check whether the electronic watch is damaged. 4. After 2 minutes of power failure, power it on again.
Console Showing E31	overtemperature	<ol style="list-style-type: none"> 1. Wait until the temperature of the machine is normal before running

CALIBRATION PROCEDURE

1. Remove the Safety Key.
2. Press and hold Start and Speed **3** buttons and at the same time replace the Safety Key. until the window displays “F1”, then press the Display **/Enter** key.
3. You will now be able to set the display to show Metric or Mile settings (Miles/E vs. Kilometers/H). You can use the speed knob key to make your selection, then press **Display/Enter** . The INCLINE window shows Grade return – ON (he stop button is pressed and does allow incline to return to zero. For sale in Europe, EU standards require this to be off) , then press Display/Enter
4. Distance window shows roller diameter. Make sure the roller size diameter is 63 then press **Display/Enter**.
5. Time window shows motor diameter. Make sure the motor size diameter is 35 then press Display/Enter.
6. The speed window shows pulley diameter. Make sure the pulley size diameter is 100 then press **Display/Enter**..
7. The speed window shows the maximum speed of 12and then press **Display/Enter**.
8. Distance window shows minimum velocity 0.5 and then press **Display/Enter**.
9. The Incline window displays maximum elevation 15 and then press **Display/Enter**.
10. Press Start button to begin calibration. The process is automatic.

Engineering Mode Menu

The console has built in maintenance/diagnostic software. The software will allow you to change the console settings from mile to Metric and turn off the beeping of the speaker when a key is pressed for example. To enter the Engineering Mode Menu, press and hold down the Start, Stop and **Display/Enter** keys. Re-power or insert Safety Key and the Time Window will display “F2”.

Use the speed knob button to make a selection and Press the **Display/Enter** key to access the menu below:

1. Key Test (Will allow you to test all the keys to make sure they are functioning)
2. Display Test (Tests all the display functions)
3. Functions (Press **Display/Enter** to access settings and Use the speed rotation button key to select)
 - I. Sleep Mode (Turn on to have the console power down automatically after 15 minutes of inactivity)
 - II. Pause Mode (Turn on to allow 5 minutes of pause, turn off to have the console pause indefinitely)
 - III. Lube Messagr Reset(Reset lube message)
 - IV. Odometer Reset (Reset odometer readings)
 - V. Units (Sets the display to readout in Mile E or Metric H display measurements)
 - VI. Beep (Turns off the speaker so no beeping sound is heard)
4. Security (Allows you to lock the keypad so no unauthorized use of the machine is allowed. When the child lock is enabled, the console will not allow the keypad to operate unless you press and hold the Start and **Display/Enter** buttons for 3 seconds to unlock the console.)
5. Exit

GENERAL MAINTENANCE

BELT & DECK

Your treadmill uses a very high-efficient low-friction deck. Performance is maximized when the deck is kept as clean as possible. Use a soft, damp cloth, or paper towel, wipe the edge of the belt and the area between the belt edge and the frame. Also reach as far as practical directly under the belt edge. This should be done once a month to extend belt and bed life. A mild soap and water solution along with a nylon scrub brush will clean the top of the textured belt. ***Allow to dry before using.***

BELT DUST

This occurs during normal break-in or until the belt stabilizes. Sometimes the black dust from the belt will appear on the floor behind the treadmill, this is normal.

GENERAL CLEANING

Dirt, dust, and hair can block air inlets and accumulate on the running belt. Please vacuum underneath your treadmill on a monthly basis to prevent excess build-up of dirt that can get sucked up and get into the inner workings under the motor cover. Every other month, you should remove the motor cover and carefully vacuum out dirt and hair that may accumulate. **UNPLUG THE POWER CORD BEFORE THIS TASK.**

BELT ADJUSTMENTS

Tread-belt Tension Adjustment - Belt tension is not critical for most users. It is very important though for joggers and runners in order to provide a smooth, steady running surface.

Adjustment must be made from the rear roller with the M6 L Allen wrench (**98**) provided in the parts package. The adjustment bolts are located at the end of the step rails as shown in the diagram below. ***Note: Adjustment is through small hole in end cap.***

Tighten the rear roller only enough to prevent slippage at the front roller. Turn the tread-belt tension adjusting bolts 1/4 turn each and inspect for proper tension by walking on the belt and making sure it is not slipping or hesitating with each step. When an adjustment is made to the belt tension, you must be sure to turn the bolts on both sides evenly or the belt could start tracking to one side instead of running in the middle of the deck.

DO NOT OVERTIGHTEN – Over tightening will cause belt damage and premature bearing failure. If you tighten the belt a lot and it still slips, the problem could actually be the drive belt located under the motor cover - that connects the motor to the front roller. If that belt is loose it feels similar to the walking belt being loose. Tightening the motor belt should be done by a trained service person.

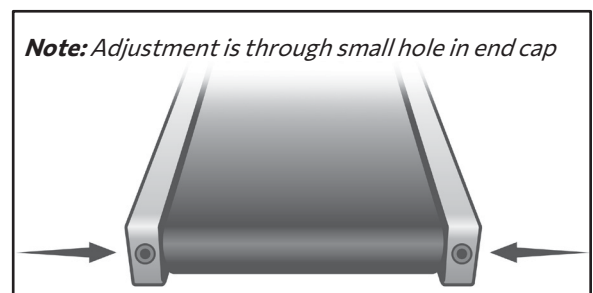

TREAD-BELT TRACKING ADJUSTMENT

The treadmill is designed so that the tread-belt remains reasonably centered while in use. It is normal for some belts to drift near one side while in use, depending on a user's gait and if they favor one leg. But if during use the belt continues to move toward one side, adjustments are necessary.

TO SET TREAD-BELT TRACKING

A 6 mm Allen wrench (**98**) is provided for this adjustment. Make tracking adjustments on the left side bolt. Set belt speed at 3 mph. Be aware that a small adjustment can make a dramatic difference which may not be apparent right away. If the belt is **too close to the left side**, then turn the bolt only a 1/4 turn to the right (clockwise) and wait a few minutes for the belt to adjust itself.

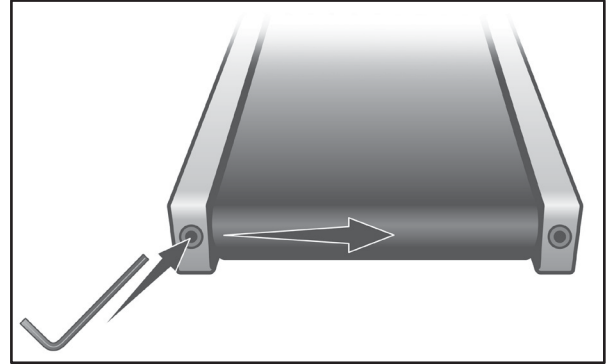

Continue to make 1/4 turns until the belt stabilizes in the center of the running deck. If the belt is **too close to the right side**, turn the bolt counter-clockwise. The belt may require periodic tracking adjustment depending on use and walking/running characteristics. Some users may affect tracking differently. Expect to make adjustments as required to center the tread-belt. Adjustments will become less of a maintenance concern as the belt is used. Proper belt tracking is an owner responsibility common with all treadmills.

ATTENTION:

DAMAGE TO THE RUNNING BELT RESULTING FROM IMPROPER TRACKING / TENSION ADJUSTMENTS IS NOT COVERED UNDER THE SOLE WARRANTY.

PREVENTATIVE MAINTENANCE CHART

Vacuum Under Motor Cover & Check Wiring (Every Other Month)	Clean & Inspect Deck for Lubrication (Every Other Month)	Lubricate Deck (Every 90 hours or sooner if dry)	Inspect Belt Tracking (Monthly) Adjust if necessary	Date

BELT/DECK LUBRICATION

First, you want to clean between the belt and deck to remove any debris that may be trapped.

Use a clean, non-fraying rag, t-shirt, or light towel. Halfway between the end of the treadmill and motor cover, shove the garment under the belt until you can grasp it on both sides of the belt. Drag the garment the length of the entire belt 1-2 times. Remove the garment.

Do not lubricate with anything other than Sole Fitness approved lubricant. 100% Food grade Silicone lubricant for treadmills. (DO NOT USE SILICONE CAULKING FOR BATHROOM AND KITCHEN PROJECTS OR A LUBRICANT THAT HAS A SPRAY/FOAM BASE)

Your treadmill comes with one tube of “Lube” and extra tubes can be ordered directly from Sole Fitness or your authorized Sole Fitness dealer. You may also use a Lube-n-Walk kit that can be purchased through both aforementioned sellers. You need to use 2-3 ounces of lubrication each application.

Keeping the deck lubricated at the recommended intervals ensures the longest life possible for your treadmill. If the lubricant dries out, the friction between the belt and deck rises and places undue stress on the drive motor, drive belt and electronic motor control board, which could result in catastrophic failure of these expensive components. Failure to lubricate the deck at regular intervals may void the warranty.

The belt & deck come pre-lubricated and subsequent lubrication should be performed every 90 hours of use, or every 90 days, regardless of usage as it can dry out, or if you notice that the deck is dry. It is recommended that you reach between the belt and deck to verify there is lubrication present, every other month. If you check and there isn't any lubrication present, follow the procedure below even though the “Lube” indicator isn't lit on the console. Otherwise, lubricate when the console's lubrication reminder lights after 90 hours of use. Use the following procedure to apply the silicone lubricant:

1. Turn the power switch off and unplug the power cord from the wall outlet
2. Measure 18” from the edge of the motor cover; kneel down and reach under the belt approximately 4- 6” from one edge. Squirt a line of lubricant about 1/8” wide x 15” long in an “S” pattern perpendicular to the motor cover.
3. Repeat the process on the opposite side.
4. Plug the electrical cord back into the outlet and turn the power switch on.
5. Walk on the belt at a moderate speed for five minutes to evenly distribute the silicone lube.
6. If the “Lube” message appears on the console, perform the following procedure to reset the message:
Power the treadmill three times to reset the lube message.

SERVICE CHECKLIST - DIAGNOSIS GUIDE

Before contacting your dealer for aid, please review the following information. It may save you both time and expense. This list includes common problems that may not be covered under the treadmill's warranty.

PROBLEM	SOLUTION/CAUSE
Display does not light	<ol style="list-style-type: none"> 1. Circuit breaker on front grill tripped. Push circuit breaker in until it locks. 2. Plug is disconnected. Make sure plug is firmly pushed into AC household wall outlet. 3. Household circuit breaker may be tripped. 4. Treadmill defect. Contact your SOLE dealer.
Tread-belt does not stay centered Treadmill belt hesitates when walked/run on	<p>The user may be walking while favoring or putting more weight on either the left or right foot. If this walking pattern is natural, track the belt slightly off-center to the side opposite from the belt movement. See General Maintenance section on Tread-belt Tension. Adjust as necessary.</p>
Motor is not responsive after pressing Start	<p>Check the problem handling based on the error code reported.</p>
Treadmill will only achieve approximately 7 mph but shows higher speed on display	<p>This indicates motor should be receiving power to operate. Low AC voltage to treadmill. Do not use an extension cord. If an extension cord is required it should be as short as possible and heavy duty 16 gauge minimum. Low household voltage. Contact an electrician or your SOLE dealer. A minimum of 120 volt AC current is required.</p>
Tread-belt stops quickly/suddenly when tether cord is pulled	<p>High belt/deck friction. See General Maintenance section on lubrication.</p>
Treadmill trips on board 15 amp circuit	<p>High belt/deck friction. See General Maintenance</p>
Computer shuts off when console is touched (on a cold day) while walking/running	<p>Treadmill may not be grounded. Static electricity is "crashing" the computer. Refer to Grounding Instructions on page 3.</p>
House circuit breaker trips, but not the treadmill circuit breaker	<p>Check that the treadmill is the only appliance in the circuit. See "Important Electrical Information" in the front of this manual for more details.</p>

MANUFACTURER'S LIMITED WARRANTY

TREADMILL WARRANTY Effective February 1, 2026

SOLE warrants all its treadmills' parts, for a period of time listed below, from the date of retail sale, as determined by sale receipt, or in the absence of a receipt eighteen (18) months from the original factory shipping date. SOLE's responsibilities include providing new or remanufactured parts, at SOLE's option, and technical support to our independent dealers and servicing organizations. In the absence of a dealer or service organization, these warranties will be administered by SOLE directly to a consumer. The warranty period applies to the following components:

Frame Weldments	Lifetime
Parts	2 Years
Labor	1 Year
Cosmetic Items*	90 Days

*Cosmetic items including, but not limited to the following: grips, console overlays, and labels/decals.

NORMAL RESPONSIBILITIES OF THE CONSUMER

This warranty applies only to products in ordinary household use, and the consumer is responsible for the items listed below:

1. The warranty registration card must be completed and returned to the address listed on the card within 10 days of the original purchase to validate the manufacturer's limited warranty or, if outside of the 10 day period, the warranty can be registered if you have proof of purchase (i.e. receipt, bank statement, credit card statement, or email order confirmation).
2. Proper use of the treadmill in accordance with the instructions provided in this manual, including general maintenance (i.e. belt tracking, belt tension, vacuuming under motor cover, and lubrication. See all components under General Maintenance section).
3. Proper installation in accordance with instructions provided with the treadmill and with all local electric codes.
4. Proper connection to a grounded power supply of sufficient voltage, replacement of blown fuses, repair of loose connections or defects in house wiring.
5. Expenses for making the treadmill accessible for servicing, including any item that was not part of the treadmill at the time it was shipped from the factory.
6. Damages to the treadmill finish during shipping, installation or following installation.
7. Routine maintenance of this unit as specified in this manual. (See All Components under General Maintenance).
8. Provide pictures or video of any issues via email as requested by the service technician. Assist with troubleshooting/diagnosing prior to a home visit.

EXCLUSIONS

This warranty does not cover the following:

1. CONSEQUENTIAL, COLLATERAL, OR INCIDENTAL DAMAGES SUCH AS PROPERTY DAMAGE AND INCIDENTAL EXPENSES RESULTING FROM ANY BREACH OF THIS WRITTEN OR ANY IMPLIED WARRANTY.

Note: Some states do not allow the exclusion or limitation of incidental or consequential damages, so this limitation or exclusion may not apply to you.

2. Service call reimbursement to the consumer. Service call reimbursement to the dealer that does not involve malfunction or defects in workmanship or material, for units that are beyond the warranty period, for units that are beyond the service call reimbursement period, for treadmill not requiring component replacement, or treadmill not in ordinary household use.
3. Damages caused by services performed by persons other than authorized SOLE service companies; use of parts other than original SOLE parts; or external causes such as corrosion (RUST), discoloration of paint or plastic, alterations, modifications, abuse, misuse, accident, improper maintenance-(see general maintenance instructions section), including lack of consistent lubrication of the deck, inadequate power supply, natural disasters, or elemental damage (i.e. power surges, lightning storms, water damage, or fire damage.)
4. Products with original serial numbers that have been removed or altered.
5. Products that have been: sold, transferred, bartered, or given to a third party. (Warranties DO NOT transfer.)
6. Products that do not have a warranty registration card on file at SOLE. SOLE reserves the right to request proof of purchase if no warranty record exists for the product.
7. THIS WARRANTY IS EXPRESSLY IN LIEU OF ALL OTHER WARRANTIES EXPRESSED OR IMPLIED, INCLUDING THE WARRANTIES OF MERCHANTABILITY AND/OR FITNESS FOR A PARTICULAR PURPOSE.
8. Product use in any environment other than a residential setting.
9. Warranties outside of North America may vary. Sole USA warranty coverage is limited to the Continental United States. Sole USA does not sell or service equipment in Hawaii, Alaska, or outside of the United States. Please contact your local dealer for details regarding warranty availability in your region.
10. Warranty will be void if the unit is not in a climate-controlled, insulated environment. (Examples: Garage, outside, carport, etc)

SERVICE

Keep your bill of sale. Twelve (12) months from the date on the bill of sale or eighteen (18) months from the date of factory shipping as determined by the serial number establishes the labor warranty period should service be required. If service is performed, it is in your best interest to obtain and keep all receipts. This written warranty gives you specific legal rights. You may also have other rights that vary from state to state. Service under this warranty must be obtained by following these steps, in order:

1. Contact your selling authorized SOLE dealer. OR
2. Submit all service requests including serial number, contact information and a brief description of the problem online at <http://www.soletreadmills.com/serviceparts.html>
3. If there is a question as to where to obtain service, contact our service department at 866-780-7653.
4. If no local service is available, SOLE will repair or replace the parts, at SOLE's option, within the warranty period at no charge for parts. All transportation costs, both to our factory and upon return to the owner, are the responsibility of the owner. The owner is responsible for adequate packaging upon return to SOLE. SOLE is not responsible for damages that occur during shipping. Make all freight damage claims with the appropriate freight carrier. DO NOT SHIP ANY UNIT TO OUR FACTORY WITHOUT A RETURN AUTHORIZATION

NUMBER. All units arriving with- out a return authorization number will be refused.

5. The service department assists in troubleshooting prior to sending a field technician. SOLE may request pictures and video via email of issues to help with diagnosing.

Before returning your Sole product to any retailer, or if you require any assistance with assembly or technical support please call us first for assistance at 866-780-7653. Thank you for your Sole purchase.

SOLE[™]
FITNESS