



***OWNER'S MANUAL
SB1200 Indoor Cycle***

*Please carefully read this entire manual
before operating your new indoor cycle.*

ATTENTION: *Before returning your Sole product to any retailer, or if you require any assistance with assembly or technical support please call us first for assistance at 866-780-7653. Thank you for your Sole purchase.*

TABLE OF CONTENTS

<u>Product Registration</u>	1
<u>Important Safety Instructions</u>	2
<u>Important Operation Instructions</u>	2
<u>SB1200 Assembly Instructions</u>	4
<u>Operation of Your New Indoor Cycle</u>	10
<u>Bluetooth® Connectivity</u>	11
<u>Maintenance</u>	15
<u>Manufacturer's Limited Warranty</u>	18



WARNING: This product can expose you to chemicals including Toluene and Acrylamide which are known to the State of California to cause Cancer and birth defects or other reproductive harm. For more information, go to www.P65Warnings.ca.gov

Before returning your Sole product to any retailer, or if you require any assistance with assembly or technical support please call us first for assistance at 866-780-7653. Thank you for your Sole purchase.

SOLE

FITNESS

CONGRATULATIONS ON YOUR NEW INDOOR CYCLE AND WELCOME TO THE SOLE FAMILY!

Thank you for your purchase of this quality indoor cycle from **SOLE**. Your new indoor cycle has been manufactured by one of the leading fitness manufacturers in the world and is backed by one of the most comprehensive warranties available. **SOLE** will do all we can to make your ownership experience as pleasant as possible for many years to come.

If there is a question as to where to obtain service, contact our service department at **866-780-7653**.

Please take a moment at this time to record below the name of the dealer, their telephone number, and the date of purchase for easy contact in the future. We appreciate your confidence in SOLE and we will always **SOLE** and we will always remember that you are the reason that we are in business. Please complete and mail your registration card today and enjoy your new indoor cycle.

Yours in Health,
SOLE Fitness

Name of Dealer _____

Telephone Number of Dealer _____

Purchase Date _____

PRODUCT REGISTRATION

RECORD YOUR SERIAL NUMBER

Please record the Serial Number of this fitness product in the space provided below.

Serial Number _____

REGISTER YOUR PURCHASE

The self-addressed product registration card must be completed in full and returned to **SOLE**. You can also go to **www.soletreadmills.com** under the support tab to register online.



IMPORTANT SAFETY INSTRUCTIONS

WARNING - Read all instructions before using this appliance. When using an electrical appliance, basic precautions should always be followed, including the following.

DANGER

To reduce the risk of electric shock:

Always unplug this appliance from the electrical outlet immediately after using and before cleaning.

WARNING

To reduce the risk of burns, fire, electric shock, or injury to persons:

1. Use this equipment only for its intended use as described in this manual. Do not attempt to ride this bike at high pedal speeds until you have ridden the bike for some time and are comfortable riding at slower pedal speeds.
2. The bike is NOT equipped with a freewheel system which means that when the flywheel is in motion, the pedals will be in motion. Do not attempt to stop the unit by applying backward pressure to pedals while they are turning as knee injury may occur. Do not attempt to remove your feet from pedals while they are moving.
3. Wait for flywheel to coast to a stop before dismounting the bike. If you want to stop the flywheel, push down on the brake knob.
4. Serious injury or death may occur from over-training. Consult a medical doctor or qualified fitness instructor to determine an exercise program appropriate for your level of fitness.
5. Do not attempt to turn the pedal cranks by hand. Do not touch any driving mechanism while it is in motion as possible injury could occur.
6. In a home setting, keep children away from the bike when it is not in use. Keep children and pets away from the unit while it is in use.
7. Do not attempt to perform dip movements on handlebars.
8. Never drop or insert any object into any opening of the bike.
9. Only use the bike on a stable, level floor.
10. Follow instructions for safe use of the equipment including proper seat position, handlebar position, and use of foot positioning system of pedals. Do not attempt to pull up handlebar post and seat post over the 'MAX' graduation.
11. For safe operation, allow for at least 1 foot (30cm) of free space to either side of the unit and 2 feet (60cm) of free space to the rear of the unit.
12. An appliance should never be left unattended when plugged in. Unplug from outlet when not in use, and before putting on or taking off parts.
13. Close supervision is necessary when this appliance is used by, on, or near children, invalids, or disabled persons.
14. Use this appliance only for its intended use as described in this manual. Do not use attachment not recommended by the manufacturer.
15. Never operate this appliance if it has a damaged cord or plug, if it is not working properly, if it has been dropped or damaged, or dropped into water. Return the appliance to a service center for examination and repair.
16. Do not carry this appliance by supply cord or use cord as a handle.
17. Keep the cord away from heated surfaces.
18. Never operate the appliance with the air openings blocked. Keep the air openings free of lint, hair, and the like.
19. Never drop or insert any object into any opening.
20. Do not use outdoors.
21. Do not operate where aerosol (spray) products are being used or where oxygen is being administered.
22. To disconnect, turn all controls to the off position, then remove plug from outlet.
23. The appliance is intended for commercial use.

Regularly examine the bike for damage and wear. Inoperable components should be replaced immediately or the equipment should not be used until it is repaired.

Failure to follow all guidelines may compromise the effectiveness of the exercise experience, expose yourself (and possibly others) to injury, and reduce the longevity of the equipment.

SAVE THESE INSTRUCTIONS - THINK SAFETY!

SAVE THESE INSTRUCTIONS

SERVICING OF DOUBLE-INSULATED PRODUCTS

In a double-insulated product, two systems of insulation are provided instead of grounding. No grounding means is provided on a double-insulated product, nor should a means for grounding be added to the product. Servicing a double-insulated product requires extreme care and knowledge of the system, and should be done only by qualified service personnel. Replacement parts for a double-insulated product must be identical to the parts they replace. A double-insulated product is marked with the words "DOUBLE INSULATION" or "DOUBLE INSULATED." The symbol (square within a square)

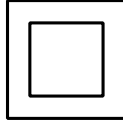

IMPORTANT OPERATION INSTRUCTIONS

WARNING - AS THE OWNER OF THIS EXERCISE EQUIPMENT, YOU SHOULD INSIST THAT ALL USERS FOLLOW THE SAME GUIDELINES: YOU SHOULD MAKE THIS MANUAL AVAILABLE TO ALL USERS.

1. Obtain a complete physical examination from your medical doctor and enlist a health/ fitness professional's aid in developing an exercise program suitable for your current health status.
2. When working out for the first time, start out slowly for a minimum of five minutes. After your muscles are warmed up, gradually increase the pedaling speed and/or resistance.
3. The speed and duration of your exercise program should always be subject to how you feel. Never permit peer pressure to exceed your personal judgment while exercising.
4. Overweight or severely de-conditioned individuals should be particularly cautious when using the equipment for the first time. Even though such individuals may not have histories of serious physical problems, they may perceive the exercise to be far less intense than it really is, resulting in the possibility of overexertion or injury.
5. Proper installation and regular maintenance are required to ensure user's safety. Maintenance is the sole responsibility of the owner.

SB1200 ASSEMBLY PACK CHECKLIST

1 HARDWARE STEP 1

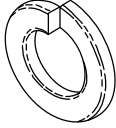
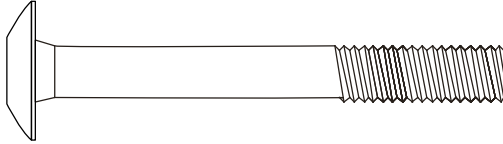
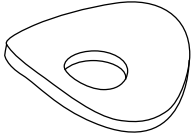
		
#94. $\text{Ø}10 \times \text{Ø}16.5 \times 2\text{T}_-$ Split Washer (4 pcs)	#93. $3/8" \times 3-3/4" _-$ Button Head Socket Bolt (4 pcs)	#95. $\text{Ø}10 \times \text{Ø}23 \times 1.5\text{T}_-$ Curved Washer (4 pcs)

2 HARDWARE STEP 2

#96. $\text{M}8 \times \text{P}1.25 \times 15\text{L}_-$ Socket Head Cap Bolt (6 pcs)

3 HARDWARE STEP 3

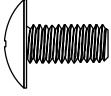
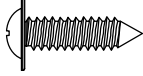
	
#80. $\text{M}5 \times 12\text{mm}_-$ Phillips Head Screw (6 pcs)	#99. $4 \times 16\text{mm}_-$ Sheet Metal Scw (5 pcs)

4 HARDWARE STEP 4

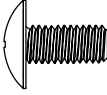
#80. $\text{M}5 \times 12\text{mm}_-$ Phillips Head Screw (4 pcs)

ASSEMBLY TOOLS

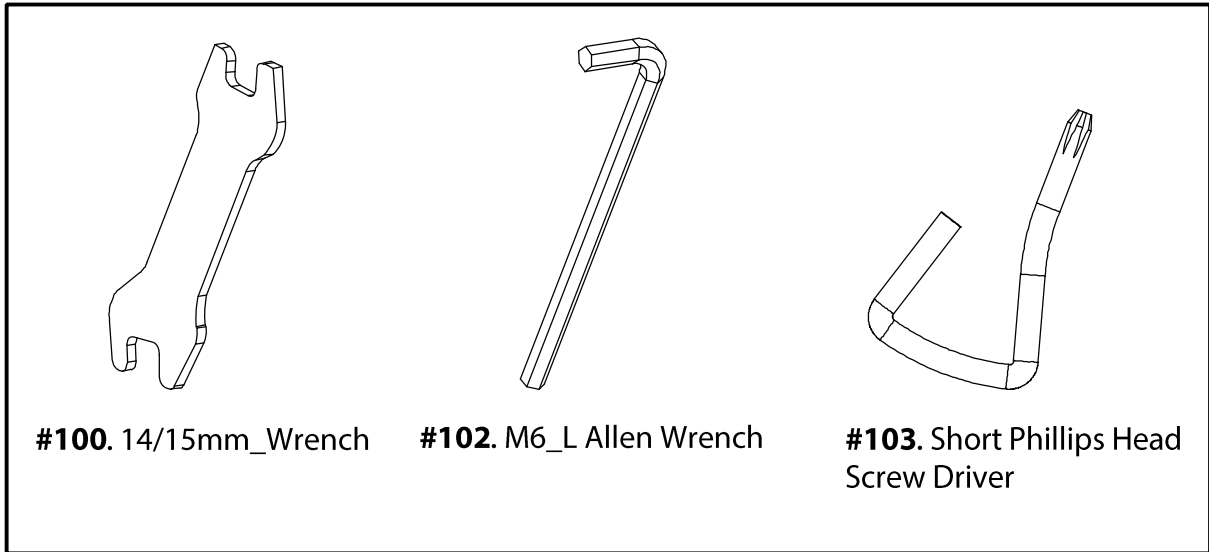

SB1200 ASSEMBLY INSTRUCTIONS

PRE-ASSEMBLY

1. Using a razor knife (Box Cutter) cut the outside, bottom, edge of box along the dotted Line. Lift Box over the unit and unpack.
2. Carefully remove all parts from carton and inspect for any damage or missing parts. If damaged parts are found, or parts are missing, contact your dealer immediately.
3. Locate the hardware package. Remove the tools first. Remove the hardware for each step as needed to avoid confusion. The numbers in the instructions that are in parenthesis (#) are the item number from the assembly drawing for reference.

1 STABILIZER TUBES

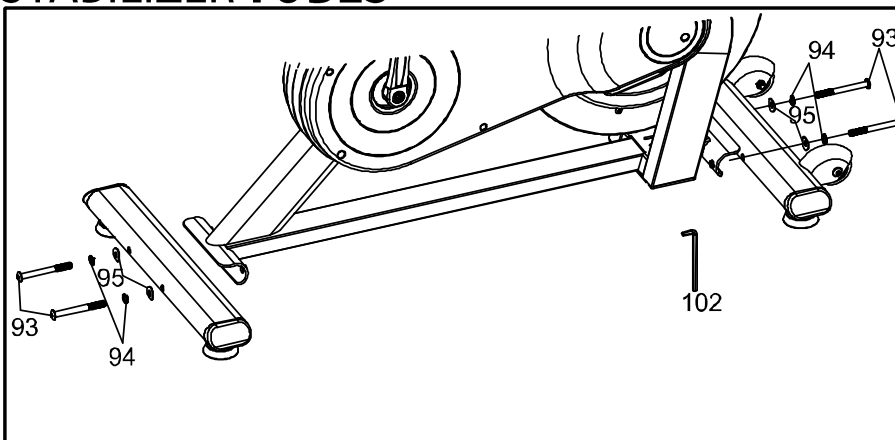

HARDWARE STEP 1

- #94. $\varnothing 10 \times \varnothing 16.5 \times 2T$ Split Washer (4 pcs)
- #93. $3/8" \times 3-3/4"$ Button Head Socket Bolt (4 pcs)
- #95. $\varnothing 10 \times \varnothing 23 \times 1.5T$ Curved Washer (4 pcs)

1. Install the Main Frame(1).Front Stabilizers (2) and Rear Stabilizers(3) with four Button Head Socket Bolts (93), four Split Washers(94) and four Curved Washers (95) by using the M6_L Allen Wrench (102).

2 SCREEN HOLDER

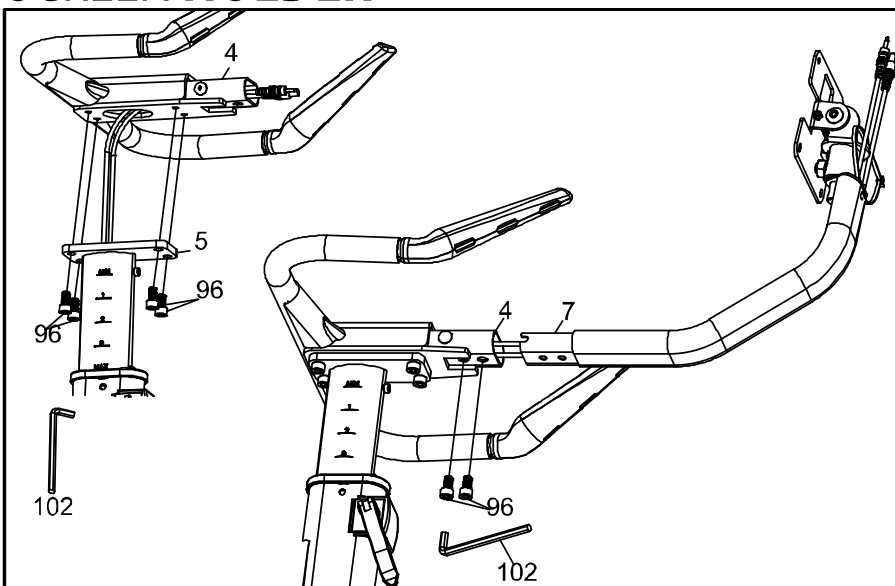

HARDWARE STEP 2

- #96. $M8 \times P1.25 \times 15L$ Socket Head Cap Bolt (6 pcs)

1. Pass the Computer Cable under the Handlebar (4), and pull it out to the front. Install the Handlebar (4) on the Handlebar Post (5) with four Socket Head Cap Bolts (96) by using the M6_L Allen Wrench (102).(Ensure that cables do not pinched.)
2. Then tie the Computer Cable to the velcro, and pass it from the Handlebar (4) to the Screen Holder (7), and pull it out of the top. Install the Screen Holder (7) on Handlebar (4) with two Socket Head Cap Bolts (96) by using the M6_L Allen Wrench (102).

3 CONSOLE

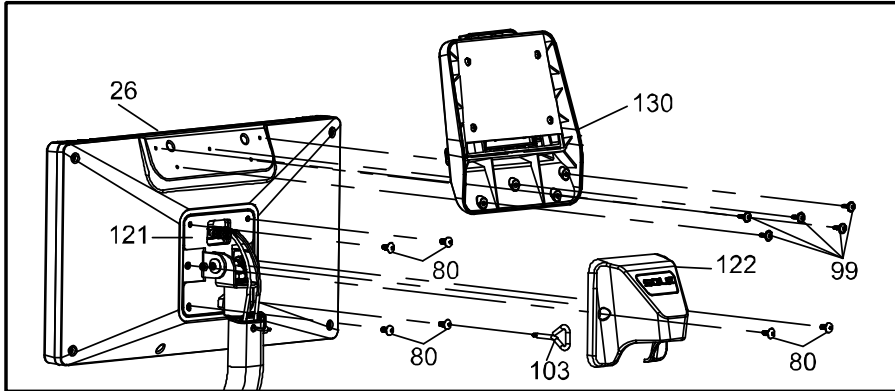

HARDWARE STEP 3

#80. M5 × 12mm_
Phillips Head Screw
(6 pcs)

#99. 4 × 16mm_
Sheet Metal Screw (5 pcs)

1. Install the Console (26) on the Screen Rack (121) with four Phillips Head Screws (80) by using the Short Phillips Head Screw Driver (103). Connect the Computer Cable to the Console (26), reserve the length of the Computer Cable for turning the Console and tighten the wire tie.
2. Install the Rotary Shaft Cover (122) on the Console (26) with two Phillips Head Screws (80) by using the Short Phillips Head Screw Driver (103).
3. Install the Tablet Holder (130) on the Console (26) with five Sheet Metal Screws (99) by using the Short Phillips Head Screw Driver (103).

4 DRINK BOTTLE HOLDER/FLYWHEEL COVER

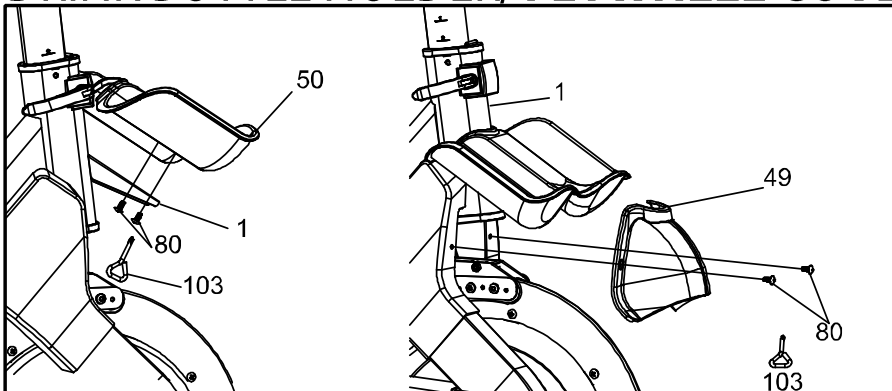

HARDWARE STEP 4

#80. M5 × 12mm_
Phillips Head Screw
(4 pcs)

1. Install the Drink Bottle Holder (50) and the Flywheel Cover (49) in front of the Main Frame(1) with four Phillips Head Screws(80) by using the Short Phillips Head Screw Driver (103).

5 DUMBBELLS HOLDER

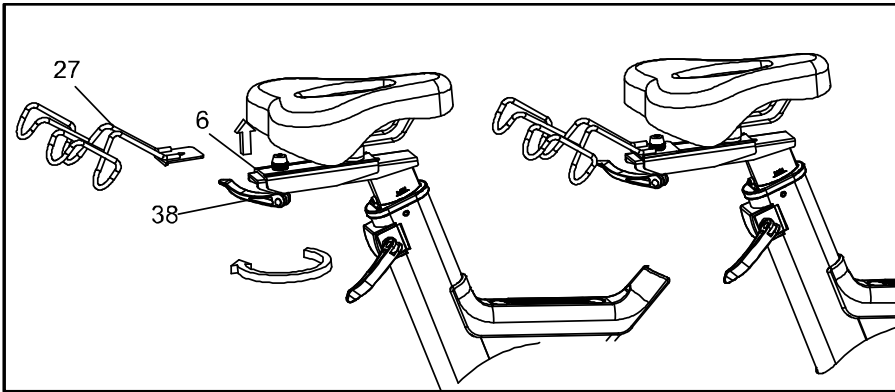

1. Unscrew the Quick Release lever(38) and place the Dumbbells Holder(27) on the Sliding Seat Mount (6) to lock the Quick Release lever(38).

6 LEFT/RIGHT PEDALS

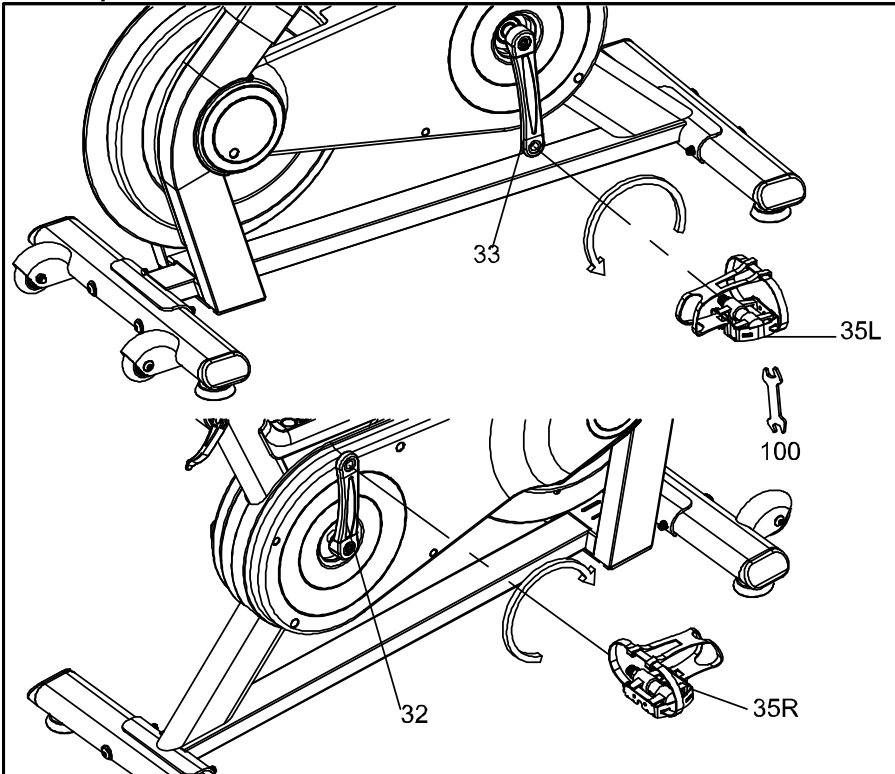

1. Install the Left (35L) and Right (35R) pedals to the Crank Arms(33&32) by using the 14/15mm_Wrench (100). Please note that the Left pedal has a reverse threaded bolt and needs to be tightened in a counterclockwise direction.

7 BRAKE TENSION KNOB

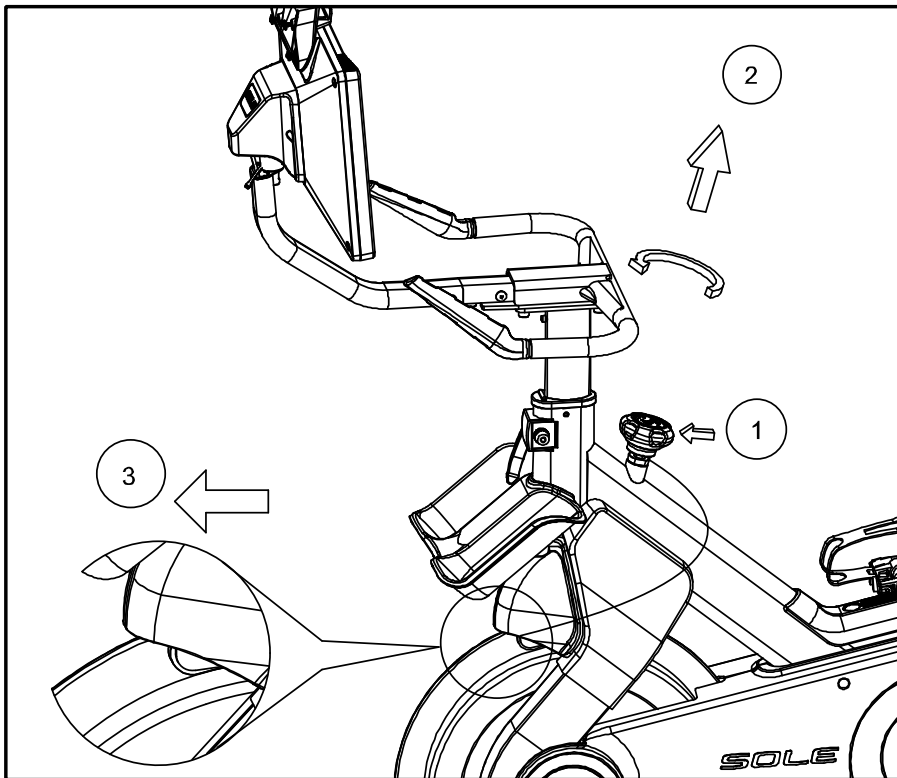

1. Loosen the flywheel and remove the Aluminum Ring Mount from the flywheel: unfasten the velcro on the knob holder ① , connect the wireless resistance knob, then turn the wireless resistance knob ② counterclockwise to the minimum value and remove the Aluminum Ring Mount ③ from the machine.

SETTING UP YOUR BIKE

Moving The Bike

Two wheels are located on the front floor mount for easily relocating the bike.

- Grip the back floor mount and tilt the bike forward (1).
- While avoiding uneven surfaces, roll the bike to its new location.
- If the bike rocks after being set down, turn each leveling foot until it rests firmly on the floor (2).

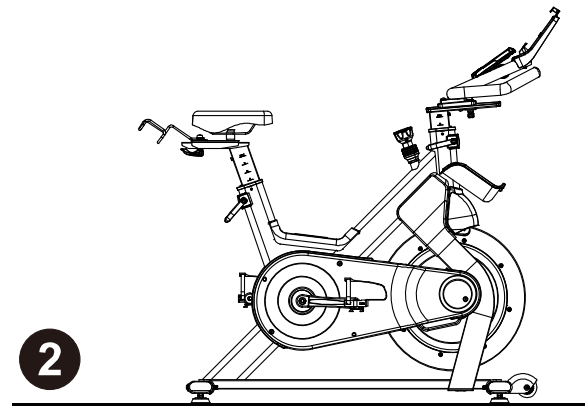
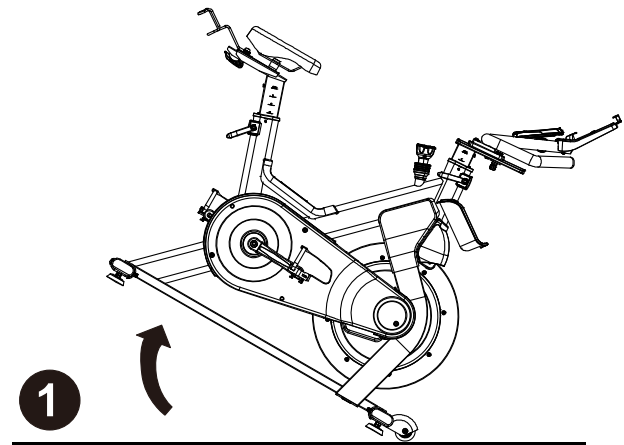

Equipment Warning

- Do not unscrew the leveling feet more than 1/2".
- Before moving your bike, adjust your handlebar and saddle settings to their lowest levels.

OPERATION OF YOUR INDOOR CYCLE

GETTING FAMILIAR WITH THE CONTROL PANEL

CONSOLE



POWER UP

When power is connected to the fitness Cycle the console will automatically power up. These models operate on DC 12V/3.3A(12V/3A) which is supplied by the power pack that is connected to 115(230) VAC. There is a power socket located where the line cord plugs into the unit on the front of the Cycle.

New SOLE + App to be used in conjunction with select Apple & Android devices!

In order to help you achieve your exercise goals, Sole has added an exciting new feature to this product. Your new exercise machine comes equipped with a Bluetooth® transceiver that will allow it to interact with compatible iOS and Android smartphones or tablet computers via the SOLE+ App.

Just download the free SOLE+ App from the Apple Store or Google Play, and follow the instructions in the App to sync with your exercise machine.

The Sole+ App also allows you to sync your workout data with one of many fitness cloud sites we support: Apple Health, Google Fit, Strava, MapMyFitness or Fitbit, with more to come.

Syncing the App with your exercise machine:

After downloading the App, make sure Bluetooth® is enabled on your device, then tap the icon at the top right corner to search for Sole equipment.

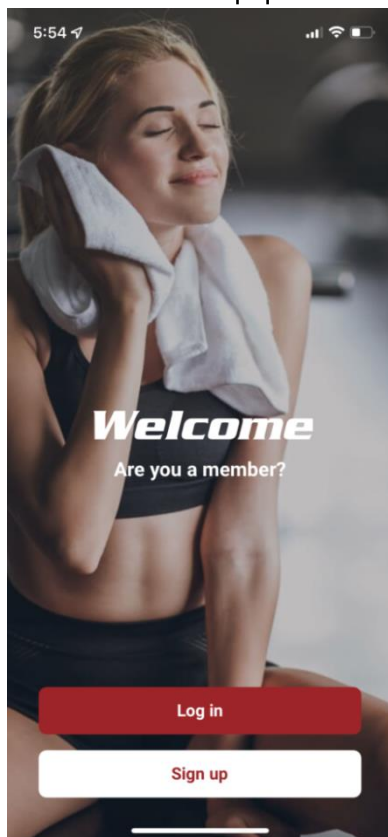

After the equipment is detected, tap Connect. When the App and equipment are synced, Bluetooth® icon on the equipment's console will light up. You may now start using your new Sole product!

Exercise equipment's Bluetooth device can also be connected to Bluetooth wireless heart rate chest strap transmitter. Chest Strap transmitter can still connect the exercise equipment even though the App has already been connected with the exercise equipment.

The exercise equipment can also play music wirelessly via Bluetooth. Turn on your mobile phone or tablet's Bluetooth function. Search for the name "Bt-speaker" in your device's Bluetooth menu. Tap to connect. Now your device can transmit music to the exercise equipment.

TOUCHSCREEN OPERATION

Use the touchscreen console to select from preset programs and enjoy media content of your choice while on the go.

The User Interface (UI) images in the manual reflect the version of software when the product was produced. The software version may be updated occasionally to include new features or repair any bugs when connected to the internet. These updates may change the UI images on the console and may no longer match the manual images.

Getting Started

Launched for the first time, the console will prompt you to either enter as a guest, or create a new profile. It is recommended to set up your own profile: it allows your machine to remember your physical parameters, and your workout records can be synchronized with the SOLE+ mobile app. Tap + to create a new profile. A maximum of 9 profiles can be created. Each profile can be protected with a passcode.

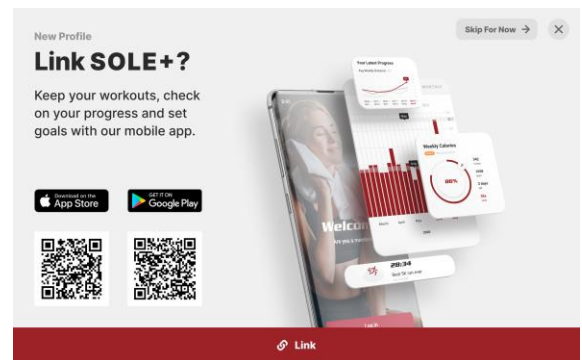
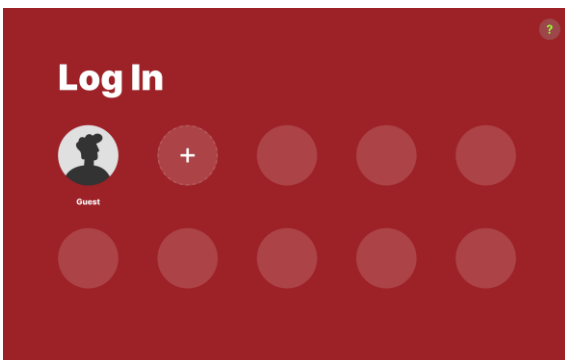

To link a SOLE+ account, scan the QR code on the console screen to download the mobile app first. Once the app is installed and the registration is complete, press “Link” on the bottom of the console screen, then open the QR code scanning camera in your SOLE+ app, and scan the QR code once again to link your local profile with the SOLE+ account. Please keep in mind that your console profile cannot be linked to multiple SOLE+ accounts at the same time. If you skip this step, you can access it again later in Profile settings.

Home Screen

The main screen of the Training section displays an overview of your activity, and offers 5 training modes: Start, Timer (Manual), Distance, Calories.

If in the Guest mode, you can set your age and weight here; it will help the machine calculate your workout summary more accurately.

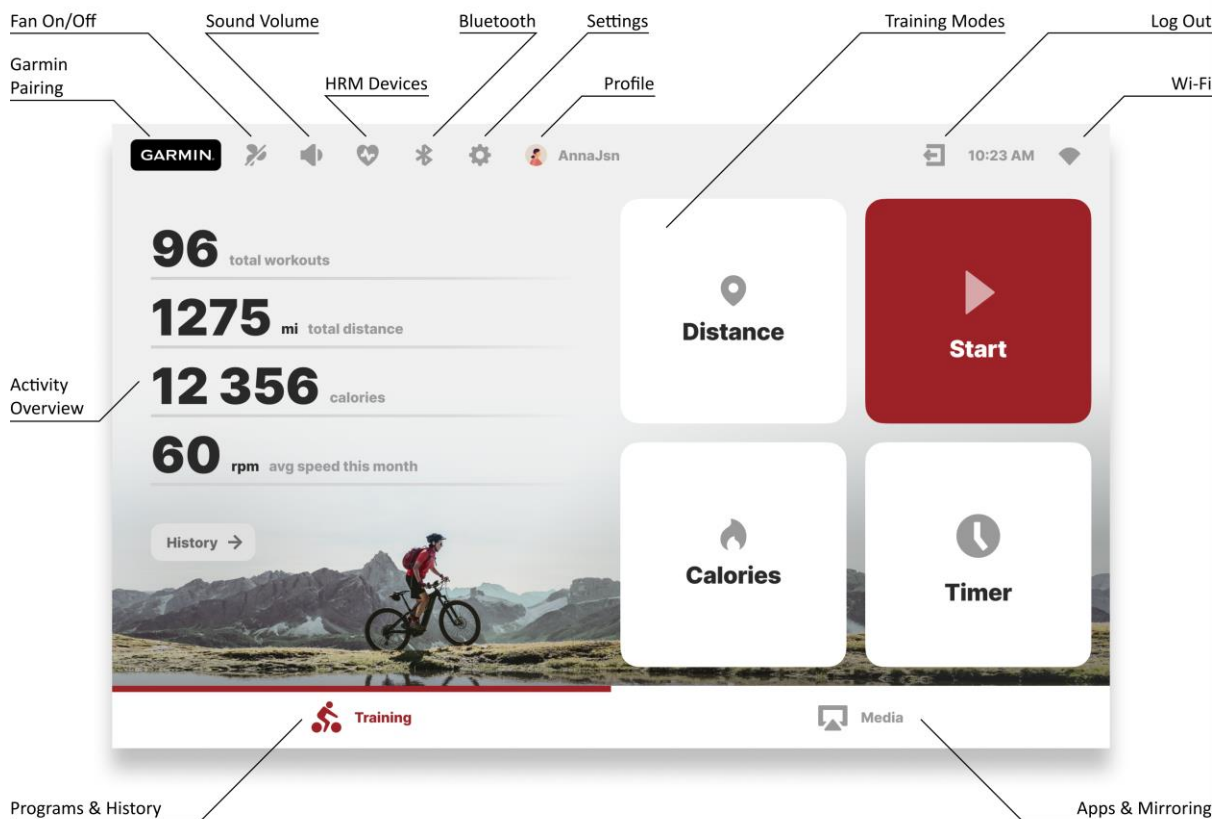

Workout Programs

Tap on any of the program cards to open a Program Setup page, where you can set properties of your workout, or switch between programs by pressing on the arrow buttons in the upper top right corner of the screen. To adjust workout parameters, you can drag the ruler, tap on the **+** and **-** buttons, or tap on the number to open a numpad and input the value directly.

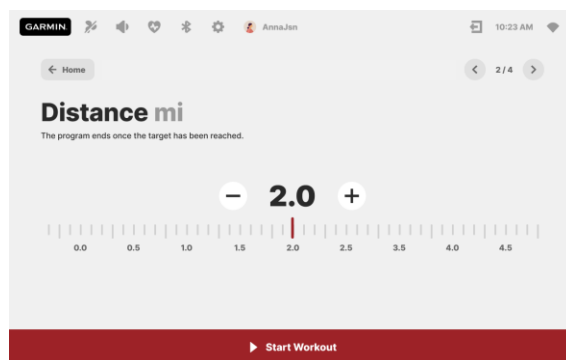
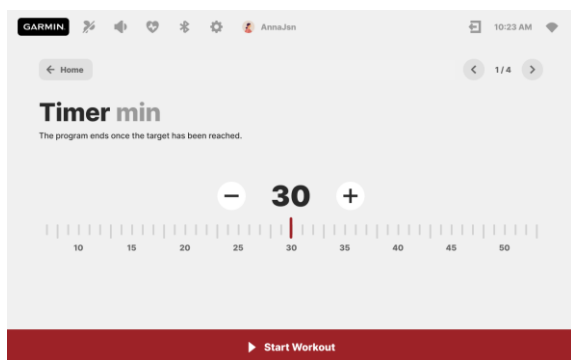

Timer (Manual) program is a timed workout with resistance level controlled manually at any time during the workout.

Distance, Calories programs set a target value for your workout. The program ends once the target has been reached.

History

To see your latest workout records, press “History” on the main screen of the Training section. Up to 10 records can be stored locally on the console, but you can access your full workout history if you link your profile to the SOLE+ mobile app. Tap on the record preview to see the full summary. Each user can only see his or her workouts.

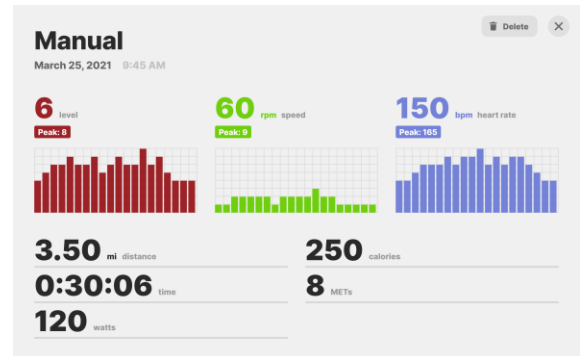
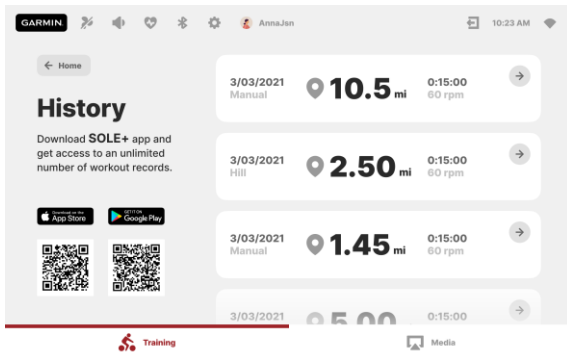

Media

Tap on the right tab of the bottom panel to access the Media section. Choose from a variety of pre-installed third party Apps, or use the Mirroring function to cast the content from your smartphone directly to the console screen. For detailed instructions, press the ? icon.

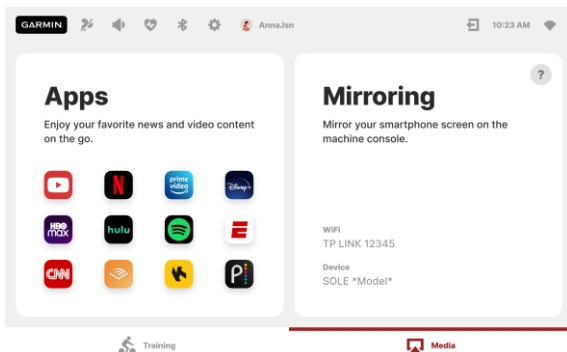

Once the content is on, use the floating panel for navigation and operating full screen mode. Touch the panel's top edge and drag the panel around the screen to find the perfect place for it, where it will not prevent you from interacting with the content. Press Hide Panels to enter the full screen mode without stats on the top and tabs on the bottom, and Show Panels to bring them back. Use the arrow button on the right side of the panel to hide & show the text labels: it allows to further minimize the panel's size. Press “Apps” to go back to the content sources selection.

Workout Mode

Once the workout has been started, the console will appear in its workout mode. During the workout, switch between **Stats** and **Charts** views of the Training section, or go to Media section to enjoy your favorite media content. In the Stats view, you can select parameters you would like to display by tapping on the number.

Please turn the knob to adjust the resistance level. Press “Pause” to pause the workout. Here, you can get back to training, or end your workout and see the summary. After 5 minutes of inactivity in the Pause mode, the workout will end automatically.

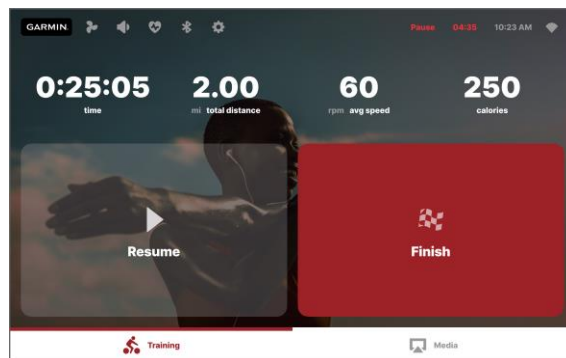
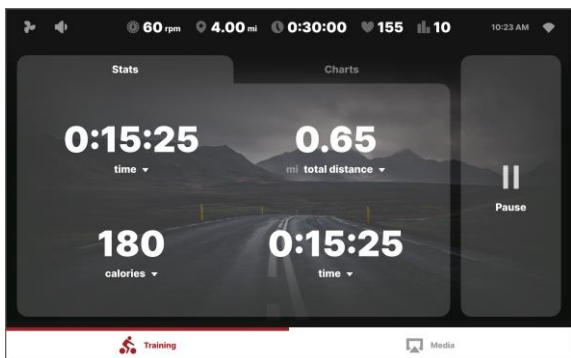

MAINTENANCE GUIDELINES

MAINTENANCE SCHEDULE

PART	RECOMMENDED ACTION	FREQUENCY	CLEANER	LUBRICANT
Pedals	Ensure that pedals are tight in crank arms; that all screws on pedals are tight; and that the pedal straps are not frayed	Before each use	N/A	N/A
Frame	Wipe down by using a soft damp clean cloth	Daily	Water	N/A
Flywheel	Wipe down by spraying on a rag and applying a light coat to sides of the flywheel	Weekly	WD-40 spray.	N/A
Brake Pad	Inspect for excessive wear or squealing	Weekly	N/A	Silicone Spray

1. Do not service internal parts of pedals. If they are found to be worn internally, we recommend replacing the pedal.
2. Use of lubricants or cleaning solutions other than those so specified will result in diminished performance and a shorter life span for that part.

FIRST TIME USER INSTRUCTIONS

ADJUSTING THE BIKE FOR A PROPER FIT

Take some time to learn how to properly adjust the bike to your body; it will make your workouts more pleasant and a safer experience too. Riding the bike when it is incorrectly adjusted can result in discomfort and increase your risk of injury.

ADJUSTMENT OF SEAT POSITION

Seat Height Adjustment

1. Standing next to the bike, adjust the seat until it is about hip height.
2. Rotate the crank arms until the pedals are in the vertical position: 12 and 6 o'clock.
3. Place your foot in the toe cage of the pedal closest to the floor and mount the bike. Ensure that the ball of your foot is over the center of the pedal. Your leg should be slightly bent at the knee, about 5 degrees.
4. If your leg is too straight or your foot cannot touch the pedal you will need to lower the seat height. If your leg is bent too much, you will need to raise the seat height.
5. Dismount the bike. Then loosen the quick release lever on the seat post and adjust up or down as necessary.
6. When the seat is in the desired position, tighten the quick release to secure the seat post.
7. Note the final position mark on the seat post for future reference.

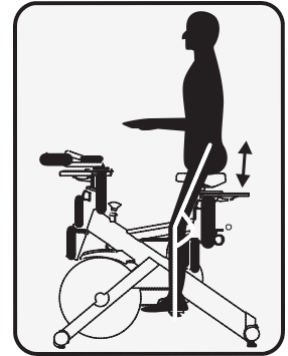

Seat Forward/Aft Adjustment

8. Sit on the bike with the crank arms in the 3 and 9 o'clock positions. A proper forward/aft position (for road bike training) of the seat is achieved when the small bump at the top of your shin is above the pedal axle.
9. Dismount the bike. Loosen the quick release under the seat and slide the seat forward or backward as desired; tighten the quick release lever.

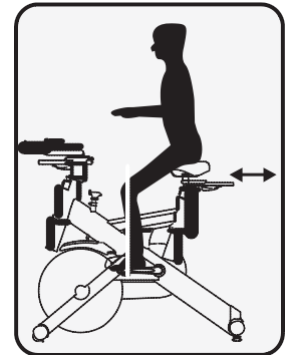

HANDLE BAR ADJUSTMENT

Handlebar Height Adjustment

1. The handlebar height is a matter of preference. Start with a handlebar height that is the same as the seat's height. Adjusting the handlebar higher will give the rider a more upright position; lower will result in a more crouched position.
2. Raise or lower the handlebar by loosening the quick release on the handlebar post and adjust by sliding the handlebar mount up or down as desired. Then tighten the quick release to secure the handlebar post. Note the final position mark on the handlebar post for future reference.

Adjustment of Handlebar's Forward/Aft Position

3. Loosen the quick release under the handlebar and slide the handlebar forward or backward as desired.
4. Tighten the quick release to secure the handlebar assembly.

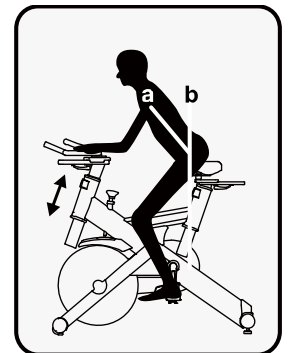

DUAL FUNCTION PEDAL

ADJUSTING THE PEDAL STRAPS

Place your feet in between the aluminum surface of the pedal and the nylon foot strap that wraps around it. If the opening is too narrow, depress the spring loaded clasp with one hand and pull on the nylon strap with the other to increase the opening area. If it is too loose or to tighten the strap, depress the spring loaded clasp, then pull on the open end of the nylon strap until the strap is snug around each foot.

USING THE CLEAT PEDALS

Engage cleated shoes in pedals by placing cleat between bindings while pushing down. Disengage by twisting heel outwards away from exercise bike.

Binding tension is adjustable and should be set so that cleat and shoe do not disengage when pedaling. Use an Allen key to turn tension adjusting screws, clockwise to increase binding tension, counterclockwise to decrease binding tension.

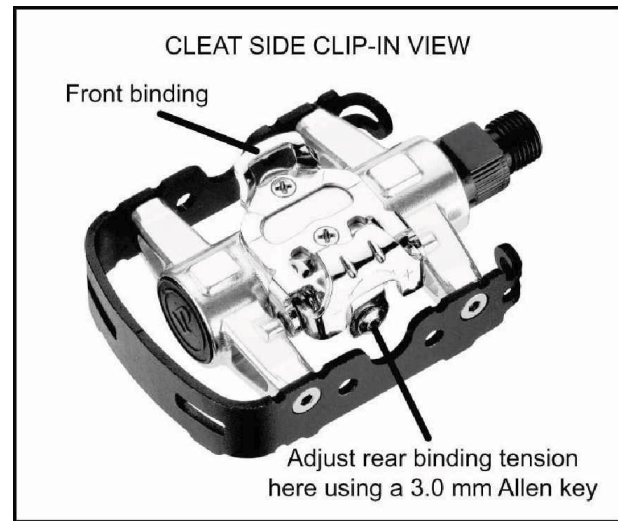
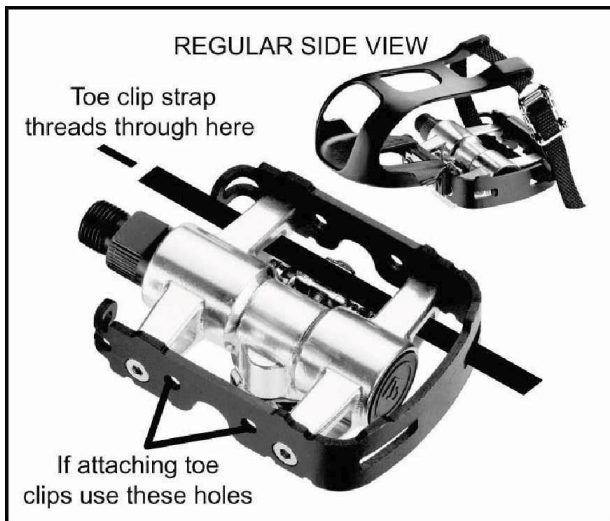

MANUFACTURER'S LIMITED WARRANTY

INDOOR CYCLE WARRANTY

Effective March 1, 2023

SOLE warrants all its indoor cycles' parts for a period of time listed below from the date of retail sale, as determined by sale receipt, or in the absence of a sales receipt eighteen (18) months from the original factory shipping date. SOLE's responsibilities include providing new or remanufactured parts, at SOLE's option, and technical support to our independent dealers and servicing organizations. In the absence of a dealer or service organization, these warranties will be administered by SOLE directly to a consumer. The warranty period applies to the following components:

Frame Weldments	Lifetime
All Other Components	2 Years
Labor	1 Year

NORMAL RESPONSIBILITIES OF THE CONSUMER

This warranty applies only to products in ordinary household use, and the consumer is responsible for the items listed below:

1. The warranty registration card must be completed and returned to the address listed on the card within 10 days of the original purchase to validate the manufacturer's limited warranty or, if outside of the 10 day period, the warranty can be registered if you have proof of purchase (i.e. receipt, bank statement, credit card statement, or email order confirmation).
2. Proper use of the treadmill in accordance with the instructions provided in this manual, including general maintenance (i.e. belt tracking, belt tension, vacuuming under motor cover, and lubrication. See all components under General Maintenance section)
3. Proper installation in accordance with instructions provided with the indoor cycle
4. Expenses for making the indoor cycle accessible for servicing, including any item that was not part of the indoor cycle at the time it was shipped from the factory.
5. Damages to the indoor cycle finish during shipping, installation or following installation.
6. Routine maintenance of this unit as specified in this manual. (See All Components under General Maintenance).
7. Provide pictures or video of any issues via email as requested by the service technician. Assist with troubleshooting/diagnosing prior to a home visit.

EXCLUSIONS

This warranty does not cover the following:

1. CONSEQUENTIAL, COLLATERAL, OR INCIDENTAL DAMAGES SUCH AS PROPERTY DAMAGE AND INCIDENTAL EXPENSES RESULTING FROM ANY BREACH OF THIS WRITTEN OR ANY IMPLIED WARRANTY.
Note: Some states do not allow the exclusion or limitation of incidental or consequential damages, so this limitation or exclusion may not apply to you.
2. Service call reimbursement to the consumer. Service call reimbursement to the dealer that does not involve malfunction or defects in workmanship or material, for units that are beyond the warranty period, for units that are beyond the service call reimbursement period, for indoor cycle not requiring component replacement, or indoor cycle not in ordinary household use.
3. Damages caused by services performed by persons other than authorized SOLE service companies; use of parts other than original SOLE parts; Or external causes such as corrosion (RUST), discoloration of paint or plastic, alterations, modifications, abuse, misuse, accident, improper maintenance-(see general maintenance instructions section), inadequate power supply, natural disasters, or elemental damage (i.e. power surges, lightning storms, water damage, or fire damage.)
4. Products with original serial numbers that have been removed or altered.
5. Products that have been: sold, transferred, bartered, or given to a third party. (Warranties DO NOT transfer.)
6. Products that do not have a warranty registration card on file at SOLE. SOLE reserves the right to request proof of purchase if no warranty record exists for the product.
7. THIS WARRANTY IS EXPRESSLY IN LIEU OF ALL OTHER WARRANTIES EXPRESSED OR IMPLIED, INCLUDING THE WARRANTIES OF MERCHANTABILITY AND/OR FITNESS FOR A PARTICULAR PURPOSE.
8. Product use in any environment other than a residential setting.
9. Warranties outside of North America may vary. Please contact your local dealer for details. Shipping charges may apply to Alaska and Hawaii customers.
10. Warranty will be void if the unit is not in a climate-controlled, insulated environment. (Examples: Garage, outside, carport, etc)

SERVICE

Keep your bill of sale. Twelve (12) months from the date on the bill of sale or eighteen (18) months from the date of factory shipping as determined by the serial number establishes the labor warranty period should service be required. If service is performed, it is in your best interest to obtain and keep all receipts. This written warranty gives you specific legal rights. You may also have other rights that vary from state to state. Service under this warranty must be obtained by following these steps, in order:

1. Contact your selling authorized SOLE dealer. OR
2. Submit all service requests including serial number, contact information and a brief description of the problem online at <http://www.soletreadmills.com/serviceparts.html>.
3. If there is a question as to where to obtain service, contact our service department at 866-780-7653.
4. If no local service is available, SOLE will repair or replace the parts, at SOLE's option, within the warranty period at no charge for parts. All transportation costs, both to our factory and upon return to the owner, are the responsibility of the owner. The owner is responsible for adequate packaging upon return to SOLE. SOLE is not responsible for damages that occur during shipping. Make all freight damage claims with the appropriate freight carrier. DO NOT SHIP ANY UNIT TO OUR FACTORY WITHOUT A RETURN AUTHORIZATION NUMBER. All units arriving without a return authorization number will be refused.
5. The service department assists in troubleshooting prior to sending a field technician. SOLE may request pictures and video via email of issues to help with diagnosing.

Before returning your Sole product to any retailer, or if you require any assistance with assembly or technical support please call us first for assistance at 866-780-7653. Thank you for your Sole purchase.

SOLE[™]
FITNESS